



info@connectder.com  
connectder.com  
2037 Washington Ave.  
Philadelphia, PA 19146  
+1 (703) 232-1427

www.solaredge.com/us/contact-us  
www.solaredge.com  
700 E Tasman Drive  
Milpitas, CA 95035  
+1 (510) 498-3200

# Installation Manual

IslandDER METER SOCKET ADAPTER V1 (V-1-D-SE)  
(for use with SolarEdge Nexis system)

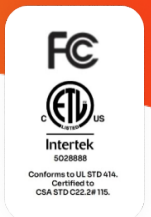
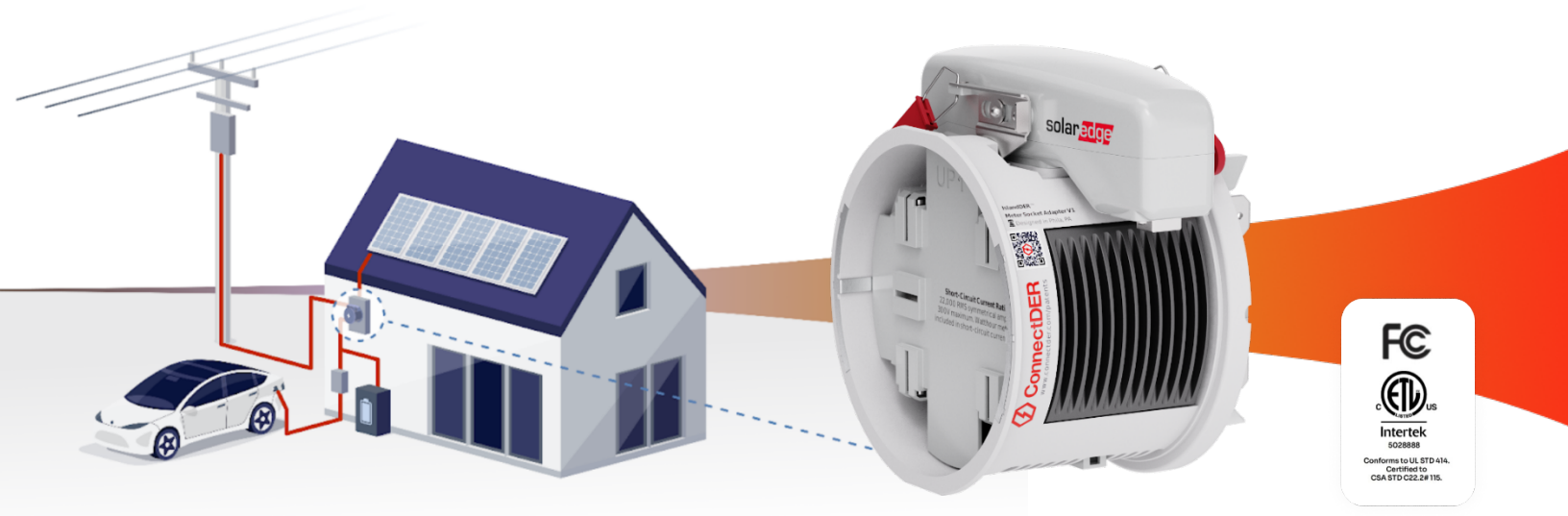

## Table of Contents

<b>ABBREVIATIONS</b> .....	<b>3</b>
<b>REVISION TABLE</b> .....	<b>4</b>
<b>SYMBOLS USED IN THIS MANUAL</b> .....	<b>5</b>
<b>IMPORTANT SAFETY INFORMATION</b> .....	<b>5</b>
<b>QUICK REFERENCE GUIDE – KEY COMPONENTS AND LEDS</b> .....	<b>7</b>
<b>INTRODUCTION</b> .....	<b>8</b>
<b>IslandDER V1 MSA FEATURES</b> .....	<b>9</b>
<b>IslandDER MSA OPERATIONAL OVERVIEW</b> .....	<b>10</b>
<b>IslandDER CONNECTION MODULE AND BASE</b> .....	<b>11</b>
<b>IslandDER SYSTEM DIAGRAM</b> .....	<b>13</b>
<b>BOX CONTENTS</b> .....	<b>14</b>
<b>INSTALLATION PREPARATION</b> .....	<b>15</b>
<b>INSTALLATION PROCEDURE</b> .....	<b>23</b>
<b>CONNECT COMMUNICATIONS CABLE TO SolarEdge Nexis BESS System</b> .	<b>36</b>
<b>LED STATUS LIGHTS &amp; TROUBLESHOOTING</b> .....	<b>45</b>
<b>MANUAL MID OVERRIDE PROCEDURE</b> .....	<b>50</b>
<b>CALIFORNIA IOU MSA PROCESS GUIDELINES</b> .....	<b>56</b>
<b>APPENDIX</b> .....	<b>57</b>
<b>Reference 1 – ETL Authorization to Mark</b> .....	<b>57</b>
<b>Reference 2 – Digital IslandDER MSA Model Number</b> .....	<b>58</b>
<b>Reference 3 – IslandDER MSA Specifications</b> .....	<b>59</b>
<b>Reference 4 – IslandDER V1 MSA Product Labels</b> .....	<b>60</b>
<b>FCC REGULATORY STATEMENT</b> .....	<b>64</b>
<b>CALIFORNIA PROP 65 WARNING</b> .....	<b>64</b>
<b>DISCLAIMER</b> .....	<b>64</b>

## ABBREVIATIONS

ANSI	American National Standards Institute
BESS	Battery Energy Storage System
Comms	Communications (Data connection to Nexis System)
CT	Current Transformer
DER	Distributed Energy Resource
ETL	Electrical Testing Laboratories (also known as Intertek)
EV	Electric Vehicle
EVPE	Electric Vehicle Power Export Equipment
EVSE	Electric Vehicle Supply Equipment
IOU	Investor-Owned Utility
LED	Light Emitting Diode
MID	Microgrid Interconnect Device
MDP	Main Distribution Panel
MSA	Meter Socket Adapter
NRTL	Nationally Recognized Testing Laboratory
RMA	Return Merchandise Authorization
PPE	Personal Protective Equipment
PV	Photovoltaic
QR Code	Quick Response Code
SPD	Surge Protective Device
UL	Underwriters Laboratories

## REVISION TABLE

Revision	Date	Change Description
C	03/30/2026	<ul style="list-style-type: none"><li>• Includes updated product renders.</li><li>• Includes updated warnings and key installation notes to reduce risk of improper installation and water ingress.</li><li>• Quick reference guide for Key Components and LEDs.</li><li>• More comprehensive overview of the Status LED.</li></ul>

## SYMBOLS USED IN THIS MANUAL



**WARNING** - Designates information highlighting the risk of death, serious injury, or damage to property.



**NOTE** - Designates information that is key to a successful installation.

## IMPORTANT SAFETY INFORMATION



**WARNING** – The IslandDER Meter Socket Adapter (MSA) must be installed by a licensed electrician or other qualified personnel. Unqualified persons attempting to install or service the IslandDER MSA could result in damage, serious injury, or death. Always follow company and local safety/PPE requirements related to OSHA and NFPA 70E.



**CAUTION:** This model of IslandDER (V-1-D-SE) can ONLY be used with SolarEdge Nexis BESS equipment that has been listed for use as a complete system.



**CAUTION** - The IslandDER MSA must be installed only with the pluggable Connection Module at the top. Do not install the IslandDER MSA in any other orientation. Installation and servicing of the IslandDER MSA, associated wiring and interconnections must be performed only by qualified personnel.

Installers must be intimately aware of local and company safety/PPE requirements. If safety/PPE requirements are unknown, STOP work. DO NOT proceed further. Installers must ensure all PPE has the minimum appropriate rating for the application.

The governing electric utility may require a power outage to deenergize the meter socket to install the IslandDER MSA. Please follow the prescribed process for work in meter sockets by the governing utility.

The installer assumes all responsibility and risks associated with the safe and intended use of the IslandDER MSA as expressed in the current installation document. Any deviation from the methods or applications in this manual will violate the product's NRTL listing, NEC Article 110.3(B), and void the product warranty.



**NOTE** - **For most installations**, an installer sourced **NEUTRAL** conductor between the MSA and the socket **DOES NOT NEED TO BE INSTALLED**. The exception is the uncommon case where a 12S meter socket has a 5<sup>th</sup> jaw at the 6 o'clock position. For more details, see section titled INSTALLATION PROCEDURE.



NOTE - Proper lock ring installation is critical to secure the MSA to the socket and prevent water ingress. Ensure the thicker flange faces the socket. If the ring is marked with “FRONT”, install with arrows facing away from the socket.



NOTE - **BOTH LATCHES** (front and rear) of the Connection Module must be fully closed and locked with the tamper-prevention seals. Failure to secure both latches could compromise ingress protection and may lead to water damage.



NOTE - The IslandDER MSA utilizes an interchangeable Connection Module that plugs into the top of the MSA Base. One is included in the box with the MSA Base, and replacement Connection Modules may also be sold and serviced as an independent accessory. This enables the Connection Module to be replaced without removing the MSA Base from the socket.



NOTE - Plan to route and support the Communications Cable from IslandDER to the SolarEdge Nexis BESS in a professional and skillful manner. Do not coil any excess slack around the meter or the MSA. Use appropriately sized and outdoor/UV rated cable clips.

Contact SolarEdge ([www.solaredge.com/us/contact-us](http://www.solaredge.com/us/contact-us)) for initial technical support regarding the installation, commissioning, or servicing of the IslandDER MSA. Always adhere to the requirements of the serving electric utility and AHJ. For additional questions or specialized hardware assistance, contact ConnectDER Support at [www.connectder.com/contact](http://www.connectder.com/contact).

## QUICK REFERENCE GUIDE – KEY COMPONENTS AND LEDS

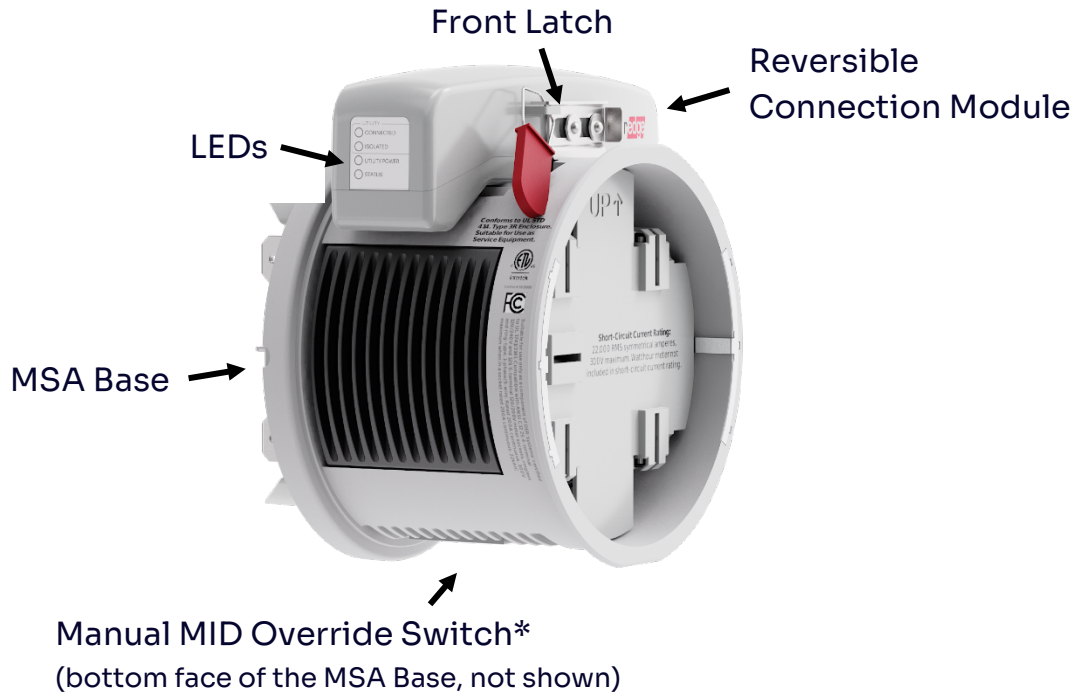

Figure 1. Key Components of the IslandDER Meter Socket Adapter (MSA). The Connection Module always sits on top of the MSA Base. \*The Manual MID Override Switch is not needed for commissioning. To be used only by qualified personnel for urgent service.



Figure 2. RJ-45 Connection Port on the MSA Connection Module. Protective boot (furnished with the MSA) not shown.

LED LABEL	STATUS
UTILITY CONNECTED	WHITE LED ON = home is connected to the utility.
UTILITY ISOLATED	BLUE LED ON = home is isolated from the utility.
UTILITY POWER	WHITE LED ON = utility power present at the MSA.
STATUS	<ul style="list-style-type: none"> <li>• <b>SOLID GREEN:</b> MSA OK, no fault.</li> <li>• <b>BLINKING GREEN:</b> Powering on. Wait a few mins until solid green.</li> <li>• <b>BLINKING RED:</b> Either a) the Manual MID Override Switch cover on the bottom face of the MSA Base has been removed, b) the comms cable to the Nexis BESS is disconnected, or c) the Nexis BESS is de-energized.</li> <li>• <b>SOLID RED:</b> Fault condition. Replace MSA.</li> </ul>

For more detailed LED troubleshooting instructions, see section titled LED STATUS LIGHTS & TROUBLESHOOTING.

## INTRODUCTION

Please read these instructions in their entirety before installing an IslandDER MSA. It is the responsibility of the party installing, replacing, and/or servicing the IslandDER MSA (“the installer”) to obtain and follow the most current installation document, found here:

LINK: <https://connectder.com/installers/>

### QR CODE



PRODUCT REGISTRATION  
& INSTALLATION MANUAL



**NOTE:** This model of IslandDER (V-1-D-SE) can ONLY be used with the approved SolarEdge Nexis BESS that has been listed for use as a complete system.



The IslandDER V1 MSA (IslandDER MSA) is a Listed device that enables rapid interconnection of interactive distributed energy resources (DERs), while avoiding service upgrades and other expensive electrical work for means of utility isolation. It provides current and voltage sensing and a microgrid interconnect device (MID) for whole-house isolation (“Islanding”) from the utility to a connected SolarEdge BESS system listed to:

- UL 1741 (Inverters, Converters, Controllers and Interconnection System Equipment for use with Distributed Energy Resources). Including applicable supplements such as SA, SB, and PCS-CRD.

The SolarEdge BESS system may also be listed to other standards such as:

- UL 9741 (Electric Vehicle Power Export Equipment (EVPE))
- UL 3141 (Power Control Systems, or PCS).
- UL 9540 (Energy Storage Systems, ESS)

Intertek grants its “ETL Listed Mark” after verifying that products meet a high level of safety and quality, and conform to numerous codes and standards. This includes the 2023 edition of the National Electrical Code (NEC) – the latest available at the time the IslandDER was developed. The IslandDER MSA conforms to UL standard 414 (including supplements A, B, and C) and is suitable for use as service equipment.

The IslandDER MSA simplifies whole- and partial-house backup power behind the meter and supports solar PV, battery energy storage systems (BESS), and other applications.

PATENTS PENDING. See <https://connectder.com/patents>.

The IslandDER MSA provides two-way data communication for the SolarEdge Nexis BESS to open or close the MID and optimize sources and loads for on-grid and off-grid operations. It has no wireless communications or power connection for external equipment. The IslandDER MSA provides wired data communications and MID control capability only.

Turn off the power supply and all other potential electricity sources before installing or servicing the IslandDER MSA. The graphics in this document depict deenergized equipment.

Comply with local codes for rules governing backfeeding power. Follow the serving electric utility’s meter removal and installation rules.

Use a calibrated voltmeter to confirm conductive parts are deenergized before touching. Install the IslandDER MSA using factory-insulated tools.

Do not alter the IslandDER MSA or any other equipment or conductor in a manner that would void its listing or warranty. There are no serviceable parts.

ConnectDER recommends practicing the installation of the IslandDER MSA using deenergized equipment before proceeding with live field installations.

## IslandDER V1 MSA FEATURES

- 15-minute installation of MID integration for Solar PV / BESS system.
- 200 amp MID relay to safely isolate (“Island”) the home for bidirectional applications.
- Manual MID override switch to provide fail-safe reclose function preventing extended outage in case of system failure.
- NRTL listed to UL 414 SA, SB, SC, for use with systems listed to UL 1741 and others such as UL 9741, UL 3141, and UL 9540.
- Provides easy access to whole-house voltage and current data (including from ANSI 0.2 Class CT’s).

- Utility meter technicians can safely remove the Connection Module for inspection and servicing.
- Compatible with ringless, ring-type, and horn or lever bypass meter sockets ANSI form 2S, 120/240v, ANSI form 12S, 120/208v, single phase, 200 amps maximum.
- 200 amp continuous rating with no fan or moving components.
- Quick-connect and quick-release pluggable weatherproof Connection Module with integrated RJ-45 connector port for digital communications via a field-furnished Ethernet cable to SolarEdge BESS system.
- The Communications Module is reversible. This permits the Ethernet cable to be routed from the left side or the right side of the meter socket to the SolarEdge BESS system.
- Internal surge protective device (SPD) for MSA internal component protection only, not to protect services and feeders as required by NEC.

## IslandDER MSA OPERATIONAL OVERVIEW

The IslandDER MSA must be connected and paired with the SolarEdge Nexis BESS specifically evaluated for use with IslandDER.

For assistance connecting and pairing to the SolarEdge Nexis system see:

[www.solaredge.com/us/contact-us](http://www.solaredge.com/us/contact-us)

The IslandDER MSA integrated MID safely isolates (“islands”) the home from the utility, allowing for microgrid operations via alternate power source(s) to the home.

The IslandDER provides voltage and current sensing to the SolarEdge Nexis BESS.

## IslandDER CONNECTION MODULE AND BASE



*Figure 3. IslandDER MSA Base and Connection Module. The Ethernet cable is used to connect the MSA Connection Module to the SolarEdge equipment. Ethernet Cable shown is example only and may not represent version required for specific installation.*

The Connection Module is equipped with an RJ-45 connector port for an Ethernet cable (furnished by the installer) to the SolarEdge Nexis BESS. Use an environmentally suitable Cat5e (or higher) Ethernet cable. For specific Ethernet cable requirements and maximum cable length, consult SolarEdge Nexis documentation.

A weatherproof ‘boot’ is furnished to terminate the Ethernet cable to the Reversible Connection Module. See Figure 4.

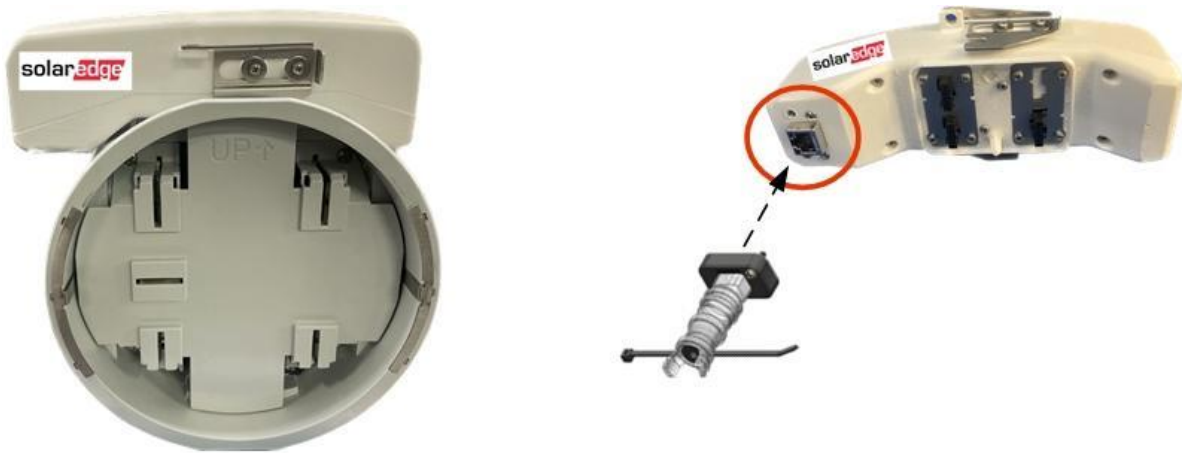

Figure 4. IslandDER MSA Base with Digital Connection Module, RJ-45 port and weatherproof boot.

Follow SolarEdge instructions to properly connect the cable to the SolarEdge Nexis BESS. Both the MSA Base and the Digital Connection Module have no serviceable parts.



**WARNING** – Follow the installation instructions for the SolarEdge Nexis BESS before connecting the Ethernet Communications Cable. The RJ-45 connector port has touch-safe potential for communication signals on its interior when the Connection Module is connected to the MSA Base in a live meter socket.

## IslandDER SYSTEM DIAGRAM

### WHOLE HOUSE BACKUP: IslandDER INSTALLED BEHIND THE UTILITY METER

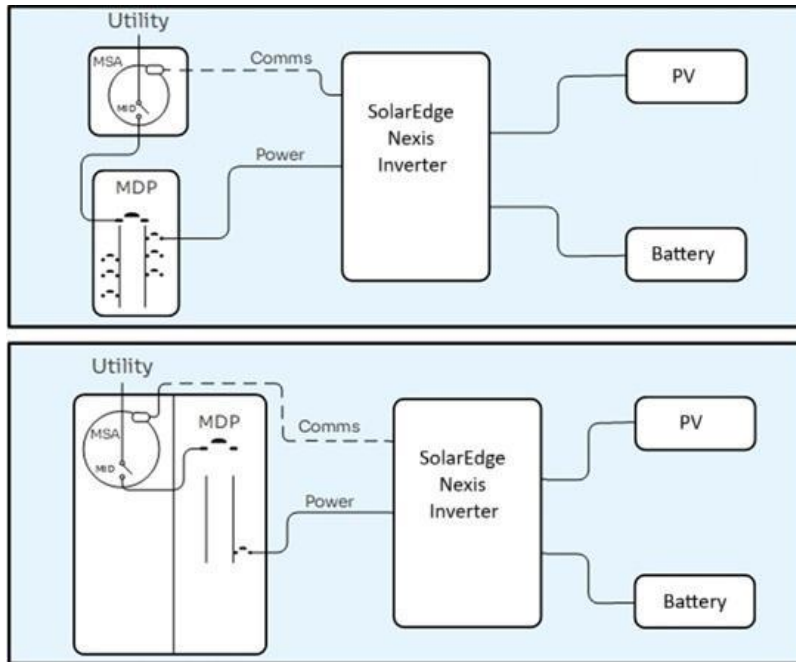

Figure 5. IslandDER installed in a Standalone Meter Socket (Top) and Meter/Main Combination Panel (Bottom).



NOTE - These configurations require permission from the serving electric utility.

The IslandDER MSA provides data to (and receives control signals from) the SolarEdge Nexis BESS shown above. Power wiring to the Main Distribution Panel (MDP), Energy Storage System (ESS), and Solar Photovoltaic (PV) components is installed by others as part of the SolarEdge Nexis system.



NOTE - IslandDER MSA is intended for use in NRTL-listed meter sockets and supports multiple installation configurations. Installers are responsible for ensuring the chosen installation configuration meets all NEC, utility, and local AHJ requirements. For questions about alternate configurations, please contact ConnectDER directly.

## BOX CONTENTS

The package contains the following items:

Qty.	Item
------	------

- |   |  |
|---|--|
| 1 | IslandDER MSA Base.  |
| 1 | Pluggable Connection Module with an RJ-45 connection port (and temporary protective 'dust cap') for an Ethernet cable (furnished by others) to the SolarEdge Nexis BESS. Includes Installation Instructions specific to the Connection Module (1-page printed front and back).   |
| 1 | Lock ring for securing the meter to the MSA.   |
| 1 | Product Registration Card with QR Code to Product Registration Form  |
| 1 | Accessory bag with installation reminders, label & QR code link to IslandDER MSA documentation. Includes: <ul style="list-style-type: none"><li>5 Tamper-resistant seals.</li><li>1 5<sup>th</sup> stab kit for 12S meter sockets (stab, lock washer, screw).</li><li>1 Installation Instructions for the installer/electrician (1-page printed front and back).</li><li>1 User Manual for the homeowner (1-page printed front and back).</li><li>1 Ethernet Boot Kit, an assembly including:<ul style="list-style-type: none"><li>1 Flexible rubber boot</li><li>1 Plastic cover plate with stainless steel hardware (2 screws)</li><li>1 Black nylon cable tie</li><li>2 Rubber grommets (two different sizes)</li></ul></li></ul> |

Verify the contents are complete before proceeding with installation. For missing or damaged items, please reach out at [www.connectder.com/contact](http://www.connectder.com/contact).

## INSTALLATION PREPARATION

### SITE INSPECTION

There are several types of residential meter sockets suitable for IslandDER MSA installation.

Some common types, namely single gang/standalone, multi-gang, and combination meter socket/load centers are covered here. All three are available in ringless and ring type configurations.



**NOTE** - Any physical obstruction created by the MSA Base or Connection Module that would impede the operation, maintenance, or inspection of the meter socket and/or main distribution panel disqualifies an IslandDER installation.

1. Assess the suitability of a meter socket by ruling out all meter sockets with signs of damage, excessive rust, evidence of loose or damaged service conductors, clearance issues and enclosures loosely secured to the structure.
2. Confirm if the serving electric utility restricts IslandDER MSA usage to ringless (Figure 6) or ring type (Figure 7) meter sockets. The IslandDER MSA supports both configurations.



Ringless meter sockets use a small raised flange to hold the meter in place with the cover closed. They do not use a separate locking ring.

Ringless meter sockets are locked through a sliding lever as shown here, or by other means implemented by the utility.

*Figure 6. Single Gang/Standalone Ringless Meter Socket.*

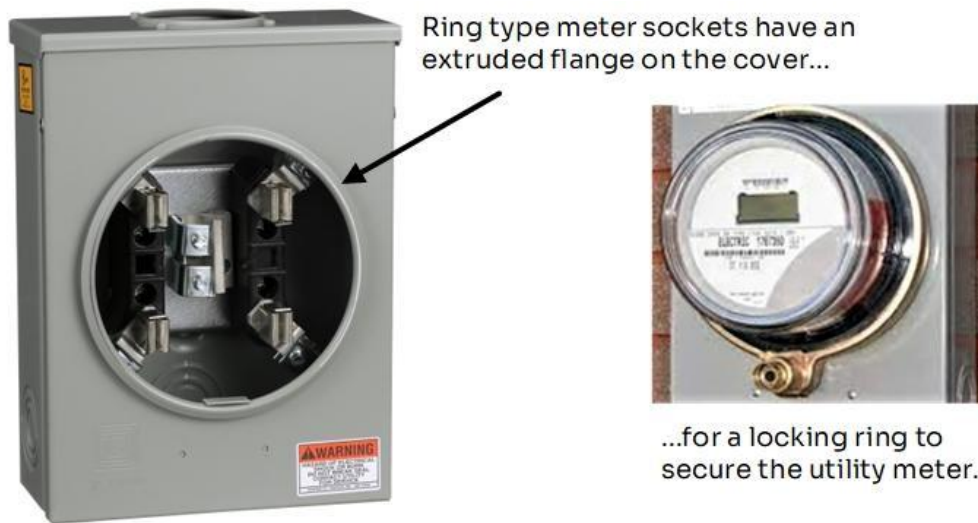

*Figure 7. Single Gang/Standalone Ring Type Meter Socket.*

3. Confirm whether multi-gang meter sockets (Figure 8) are on the utility’s approved equipment list. They may present service access/clearance issues versus single gang meter sockets. ConnectDER recommends researching the manufacturer’s documentation for potential compatibility.

IslandDER MSA compatibility with multi-gang meter sockets may be permitted by the utility on a case-by-case basis. Care must be taken to ensure that the IslandDER MSA Connection Module can be fully inserted and disconnected without obstruction from adjacent meters/equipment.

Multi-gang meter sockets may accommodate only the top socket, or left & right sockets, or possibly none. Always check with the serving utility.



*Figure 8. Multi-Gang Meter Sockets.*

4. Confirm that combination meter socket/load centers (Figure 9) are on the utility's approved equipment list. They may present service/clearance access issues over single gang meter sockets. ConnectDER recommends researching the manufacturer's documentation for potential compatibility.



*Figure 9. Combination Meter Socket / Load Centers.*



**WARNING** – Do not alter the IslandDER MSA or any other equipment in a manner that voids its listing or warranty.



**NOTE** - Only install IslandDER in a Top Door Combination Meter Socket / Load Center **IF the MSA Base and fully seated Connection Module do not inhibit normal access to the adjacent compartments.**

5. An IslandDER MSA shall not be installed on meter sockets already equipped with another socket adapter as shown in Figure 10.



*Figure 10. Existing Meter and Meter Socket Adapter.*

6. Account for other considerations:

- a. Check with the utility for other potential IslandDER MSA prohibited installations. Do not install an IslandDER MSA where it is subject to physical damage.
- b. Verify the IslandDER MSA model number(s) approved for use in the utility's service area.
- c. Verify the IslandDER MSA would be accessible after the installation with adequate working clearance. The IslandDER MSA extends the billing meter approximately 5 inches forward from the meter socket.
- d. Check with the utility and AHJ before installing an IslandDER MSA indoors. For example, the AHJ may not permit the IslandDER MSA in bathrooms, or over the steps of a stairway.
- e. Verify the existing meter indicates the service is ANSI form 2S, 120/240v, ANSI form 12S, 120/208v, single phase, 3-wire, 200 amps maximum. Some utilities require 12S/5-jaw meter sockets but are installing 2S/4-jaw meters. The IslandDER MSA is furnished with a 5<sup>th</sup> stab kit to support 12S/5-jaw meter sockets with the 5<sup>th</sup> jaw at the 9 o'clock position.

7. Additional examples of meter sockets **NOT suitable** for an MSA installation:

- a. Meter socket enclosures with damage, excessive rust, or are poorly mounted. See Figure 11.



*Figure 11. Rusty, Damaged, Poorly-Mounted Meter Sockets.*

- b. Meter sockets with signs of corrosion or overheating as shown in Figure 12.

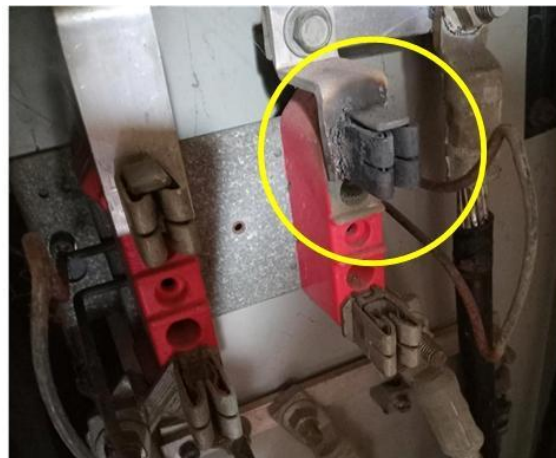

*Figure 12. Corroded Jaw.*

- c. Meter sockets where IslandDER MSA installation **inhibits access to adjacent compartments / service disconnects / breakers**. Figure 13 depicts a Top Door Combination Meter Socket / Load Center, which is typically not suitable for MSA installation since the MSA’s Connection Module often inhibits access to the service disconnect / breaker enclosure.



Figure 13. Top Door Combination Meter Socket / Load Centers. Once the Connection Module is installed on top of the MSA Base, IF it inhibits access to the service disconnect / breaker enclosure, this meter socket is NOT suitable for an MSA installation.

8. Confirm the existing utility meter is either form 2S or 12S, 3-wire, 200 amps maximum. See Figure 14



Figure 14. Meter Form 2S and 12S.



NOTE – A 2S meter has 4 stabs. It fits into (and operates properly) in meter sockets with either 4 or 5 jaws. A 2S meter does not operate properly when a 5-jaw socket is used with a 120/208V system.

If the utility meter is form 12S (5 stabs), OR if the existing meter socket has 5 jaws (even if a form 2S/4-jaw meter is installed), follow the steps in the INSTALLATION PROCEDURE to install the 5<sup>th</sup> stab that is furnished with every unit.

9. A meter socket in good condition should have (1) tight conductor connection with no corrosion, (2) insulation blocks not cracked or broken, (3) jaws that tightly grip the meter stabs with no gaps, pits, or corrosion, and (4) conductor insulation intact and not frayed or cracked. See Figure 15.

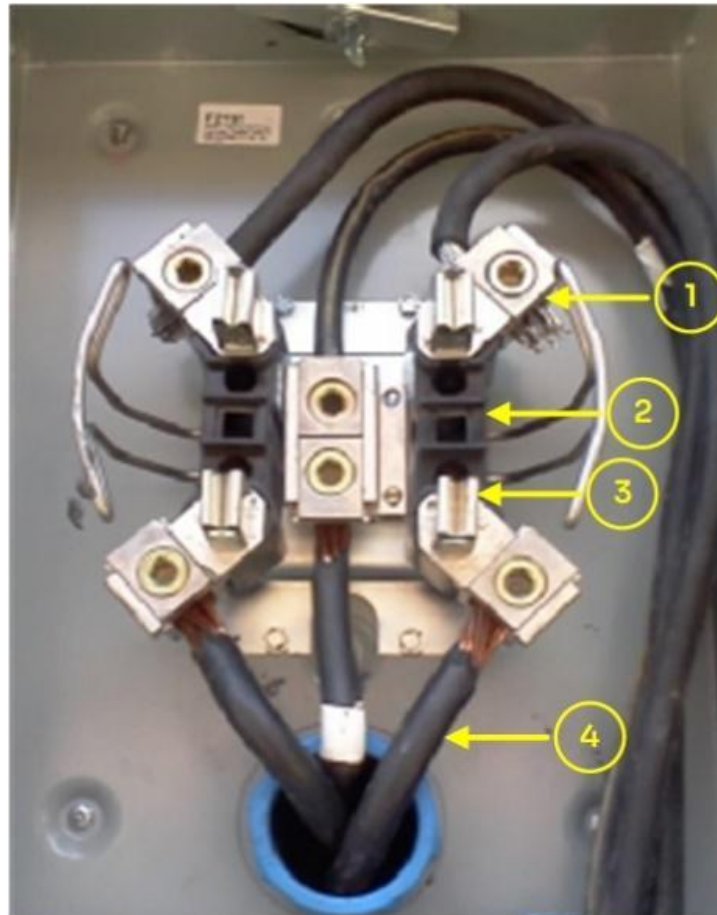

*Figure 15. Existing meter socket in good condition.*

## PACKAGE INSPECTION

Inspect the box and verify the contents are complete and in good condition. For missing or damaged items, please reach out at [www.connectder.com/contact](http://www.connectder.com/contact).

## ITEMS REQUIRED FOR IslandDER MSA INSTALLATION



NOTE – The following items must be provided by the installer to install an IslandDER MSA into a meter socket. Use factory-insulated tools wherever possible. Communications wiring installation is covered later in this document. For installs in California, please refer to the section called CALIFORNIA IOU MSA PROCESS GUIDELINES for additional requirements.

Qty.	Item
------	------

- |   |  |
|---|--|
| 1 | Wire cutter, e.g., diagonal pliers.  |
| 1 | “Meter Grabber™” or equivalent tool to safely remove and reinstall the electric meter. |
| 1 | Calibrated digital volt-ohmmeter or other suitable metering equipment.                 |
| 1 | Small plastic bag and 1 roll of electrical tape for cable plug protection.             |

The following items are only required for meter sockets w/5th jaw at the 6 o’clock position:

- |        |   |
|--------|---|
| 1      | Wire stripper.  |
| 1      | Approved wiring connector (if needed) and tools to terminate a #10 AWG stranded copper conductor (furnished by others) inside the meter socket. |
| 1      | 5/32” hex key.  |
| 1      | 5/32” hex bit for use with a torque driver.   |
| 1 lot  | Electrical insulation blanket.  |
| 1      | Calibrated torque driver, minimum setting 35 in. lbs.   |
| 18 in. | #10 AWG THHN stranded copper Neutral wire.  |



NOTE – In most cases a neutral wire will NOT be installed (i.e. in 2S/4-jaw sockets, or 12S/5 jaw sockets with 5<sup>th</sup> jaw at 9 o’clock position).

Only meter sockets with the 5<sup>th</sup> jaw at the 6 o’clock position will require a neutral wire (requires replacing the existing meter with an ANSI 12S meter, with its 5<sup>th</sup> jaw at the 9 o’clock position). Please refer to the section called INSTALLATION PROCEDURE later in this document.

## SAFETY EQUIPMENT

Always follow company and local safety/PPE requirements related to OSHA and NFPA 70E.

Installers must be intimately aware of local and company safety/PPE requirements. If safety/PPE requirements are unknown, STOP work. DO NOT proceed further. Installers must ensure all PPE has the minimum appropriate rating for the application.

Examples of common PPE and other protective devices are listed below:

Qty.	Item
1	Safety glasses.
1	Full-face arc flash shield.
1	Leather/rubber insulated electrical glove kit.
1 lot	Calorie rated clothing for the site's arc flash rating.
1 pair	Safety footwear.

If utility power cannot be deenergized as part of the MSA installation, ConnectDER recommends insulating energized parts within the meter socket. Work safely when installing a #10 AWG neutral wire to the MSA to accommodate a replacement ANSI 12S meter with its 5<sup>th</sup> jaw at the 9 o'clock position. Use an appropriately rated electrical insulation blanket that can be cut to size and temporarily applied. See Figure 16.



Figure 16. Protection From Energized Parts.

## INSTALLATION PROCEDURE



**WARNING** – IslandDER MSA installation must be performed by qualified personnel only. Electric shock, arc flash hazards, serious injury or death may result if power is not removed prior to the IslandDER MSA installation.



**NOTE** – In some service territories, the meter must be removed by the utility. An increasing number of utilities are permitting qualified personnel to remove the meter and install the IslandDER MSA.

The serving electric utility may require a power outage to deenergize the meter socket. Please follow the prescribed process for work in meter sockets by the utility.

For meter sockets with a 5<sup>th</sup> jaw at the 9 o'clock position, install the 5<sup>th</sup> stab kit as directed below in the "IslandDER MSA INSTALLATION INSTRUCTIONS".

\*\*\*In less common meter sockets with a 5<sup>th</sup> jaw at the 6 o'clock position, coordinate with the utility in advance to change the billing meter to form 12S with the 5<sup>th</sup> stab at the 9 o'clock position. A #10 AWG neutral wire will need to be installed to one of the neutral terminals on the rear of the MSA if performing a form conversion.\*\*\*

Follow the instructions below in the "IslandDER MSA INSTALLATION INSTRUCTIONS" to install the 5<sup>th</sup> stab at the 9 o'clock position, AND install a #10 AWG copper neutral wire (if applicable).

## INSTALLATION PLANNING INSTRUCTIONS

1. Plan to route and support the Ethernet Communications Cable from the IslandDER MSA to the SolarEdge Nexis BESS in a professional and skillful manner.

The installer must furnish an Ethernet cable to the SolarEdge Nexis BESS and use the Ethernet boot kit included with the MSA to keep the RJ-45 port weatherproof.

Use a Cat5e or higher Ethernet cable suitable for its environment. Test cable integrity using an Ethernet cable tester before connecting.

2. Determine the desired orientation of the Connection Module. The Communications Cable may exit to the left or to the right.
3. Comply with working clearances and access to equipment as required by the utility and authority having jurisdiction (AHJ).
4. If the IslandDER MSA is installed prior to connection to the SolarEdge Nexis BESS, keep the pre-installed dust cap secured over the RJ-45 port. The RJ-45 connector port has touch-safe potential for communication signals on its interior when the Connection Module is connected to the MSA Base in a live meter socket.



NOTE - Some electric utilities are installing the IslandDER MSA themselves and require the balance of the DER system to be installed first. Please refer to the section called CALIFORNIA IOU MSA PROCESS GUIDELINES later in this document.

## IslandDER MSA INSTALLATION INSTRUCTIONS

1. Open the box and remove all the contents.
2. For a form 12S meter socket with a 5<sup>th</sup> jaw at the 9 o'clock position, locate the 5<sup>th</sup> stab kit (Figure 17). For a 2S meter socket, skip to step 4.



*Figure 17. 5<sup>th</sup> Stab Kit.*

3. Attach the 5<sup>th</sup> stab to the rear of the MSA Base at the 9 o'clock position (Figure 18) using a #0 or #1 Philips screwdriver until the screw is fully seated. Torque to 5 in. lbs.

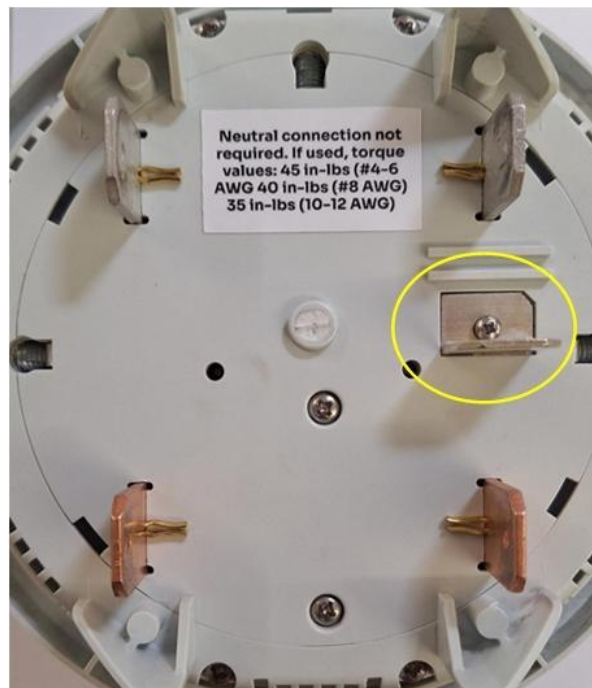

*Figure 18. 5<sup>th</sup> Stab Kit with 5<sup>th</sup> jaw at 9 o'clock.*

4. Remove all jewelry, **put on the appropriate PPE**, and follow your employer's safety procedures.
5. Notify the homeowner that power will be interrupted.
6. Turn OFF the premises main service disconnect.
7. Cut and remove the utility tamper-prevention seals and remove the lock ring (and socket cover if ringless).
8. For lever bypass meter sockets, actuate the lever to permit meter removal.
9. Using a "Meter Grabber™" or similar tool, remove the utility meter and store it safely.
10. Inspect the meter socket terminals for loose or broken wires, damaged jaws, and other signs of damage. Confirm the meter socket and service entrance conductors are in good condition before proceeding.
11. Actuate the lever bypass, if any, to deenergize the load side jaws.
12. **IF a Neutral pigtail is required (ONLY for 12S meter sockets with a 5th jaw at the 6 o'clock position. Skip this step for all other cases):**
  - a) Cover the line side jaws with an electrical insulation blanket. See Figure 19.
  - b) Install a #10 AWG copper stranded neutral wire from the meter socket interior.



*Figure 19. Meter socket with 5<sup>th</sup> jaw at 6 o'clock.*

- c) For ring-type meter sockets, reinstall the meter socket cover, routing the neutral through the cover. Terminate the other end to the MSA neutral terminal at either its 3, 9, or 12 o'clock position. Torque to 35 in-lbs. using a 5/32" hex bit. See Figure 20.

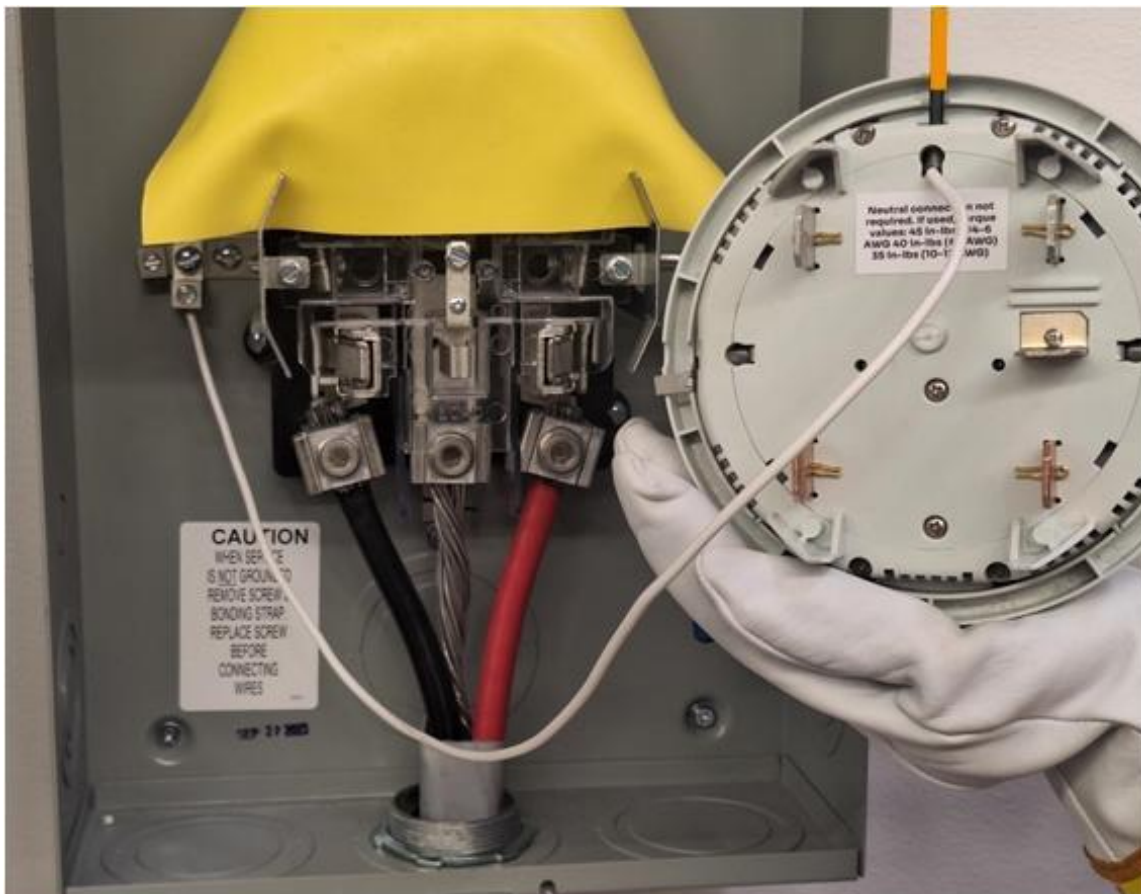

*Figure 20. Field-Supplied Neutral Connection for Meter Sockets with 5<sup>th</sup> Jaw at 6 o'clock.*

- d) Remove the electrical insulation blanket, if used.
13. For lever bypass sockets, actuate the lever to permit meter base installation.
  14. Insert the MSA Base into the meter socket with the Connection Module contacts at the top. Ensure it is fully and securely seated. See Figure 21.



*Figure 21. MSA Base Inserted in ringless socket.*

15. For lever bypass meter sockets, return the lever to the normal position.
16. For ringless meter sockets, reinstall the meter socket cover over the MSA Base. Proceed with caution as the MSA line side jaws are now energized.
17. For ring-type meter sockets, install a lock ring to secure the MSA base to the meter socket cover with the thicker/wider flange facing the meter socket. If the lock ring says “Front” on it, install it with the arrow facing away from the meter socket as shown in Figure 22.

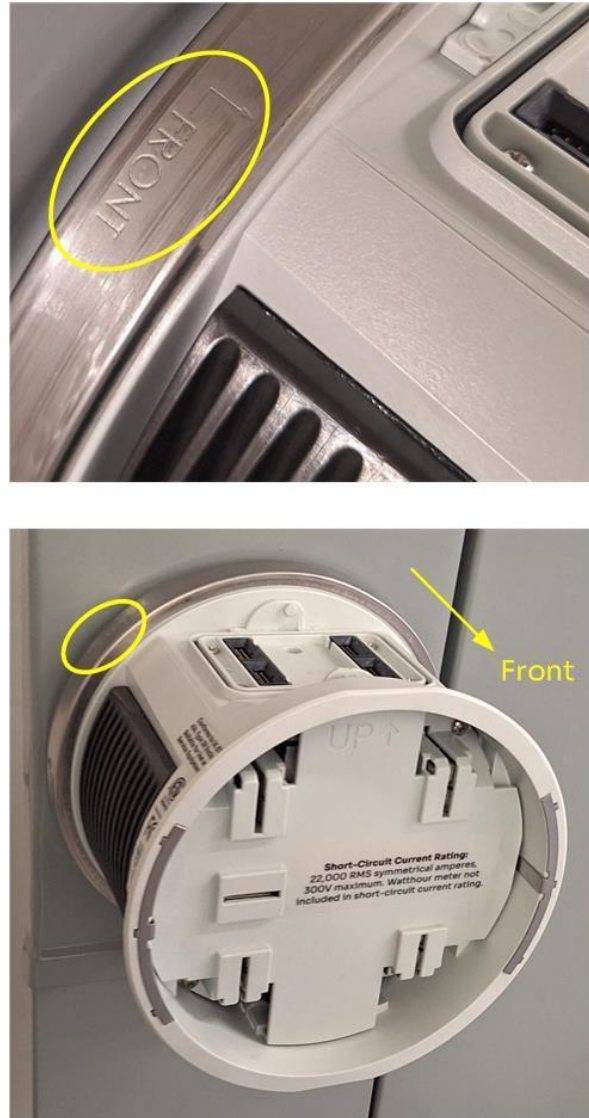

Figure 22. MSA Base installed in ring type socket with Lock Ring Installed.



NOTE - Proper lock ring installation is critical to secure the MSA to the socket and prevent water ingress. Ensure the thicker flange faces the socket. If the ring is marked with “FRONT”, install with arrows facing away from the socket.

18. Using a “Meter Grabber™” or similar tool, reinstall the utility meter, or install the new replacement utility meter.
19. Install a lock ring to secure the utility meter to the MSA Base with the thicker/wider flange facing the meter socket. If the ring says “Front” on it, install it with the arrow facing away from the meter socket. See Figure 23.



Figure 23. MSA Base with Utility Meter Installed.

20. Note the guide pins on the bottom of the Connection Module. See Figure 24. Slide the front and rear latches to the open position.

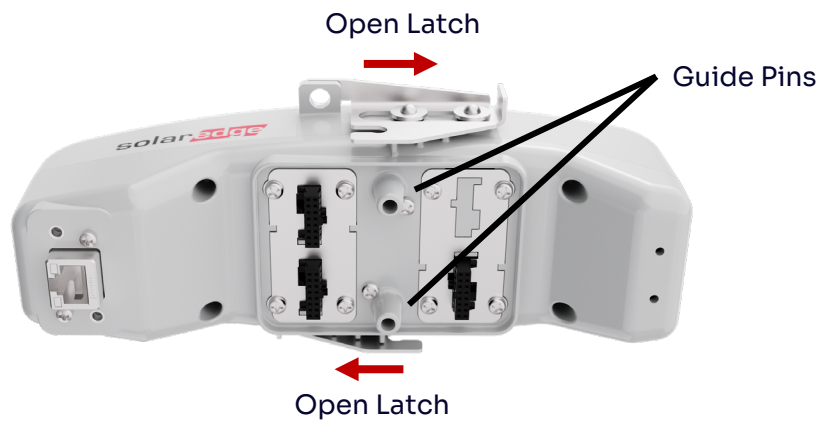

Figure 24. Connection Module Guide Pins and Latches.

21. Confirm the Connection Module contacts at the top of the MSA Base are clear of any debris. Position the Connection Module above the MSA Base with the Communications Cable exiting toward the desired direction.



**WARNING:** The pins within the MSA base are fragile. Proceed with caution to avoid bending or damaging the pins.

22. Align the Connection Module guide pins with the holes in the MSA Base. See Figure 25. **Level** the connection module and **carefully** insert it into the top of the MSA Base.



*Figure 25. Insert the Connection Module.*

23. Slide the front and rear latches to secure the Connection Module to the MSA Base as shown in Figure 26.



Figure 26. Slide the latches closed.

24. Turn ON the premises main service disconnect to restore utility power.
25. Install tamper-prevention seals on the lock rings, the meter socket cover, and the two Connection Module latches.



**NOTE - BOTH LATCHES** (front and rear) of the Connection Module must be fully closed and locked with the tamper-prevention seals. Failure to secure both latches could compromise ingress protection and may lead to water damage.

26. Check the LED status on the Connection Module on the opposite end from the Ethernet Port. Confirm the 'Utility Connected' white light is on, and the 'Status' LED is solid green after blinking a few minutes. If the IslandDER MSA is not connected to the BESS, the 'Status' LED may be blinking red. See Figure 27.

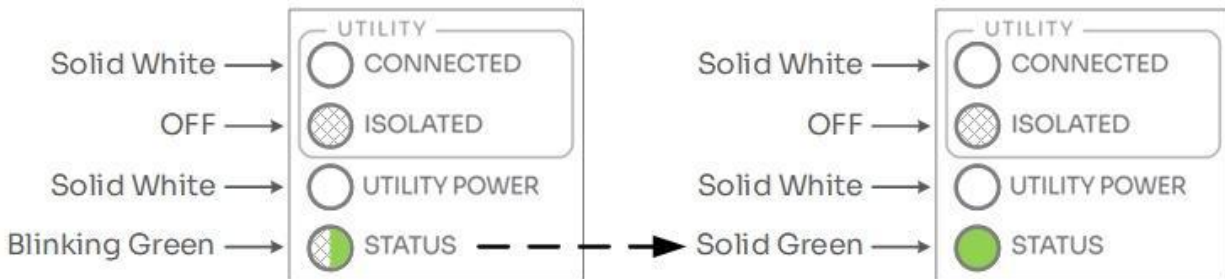
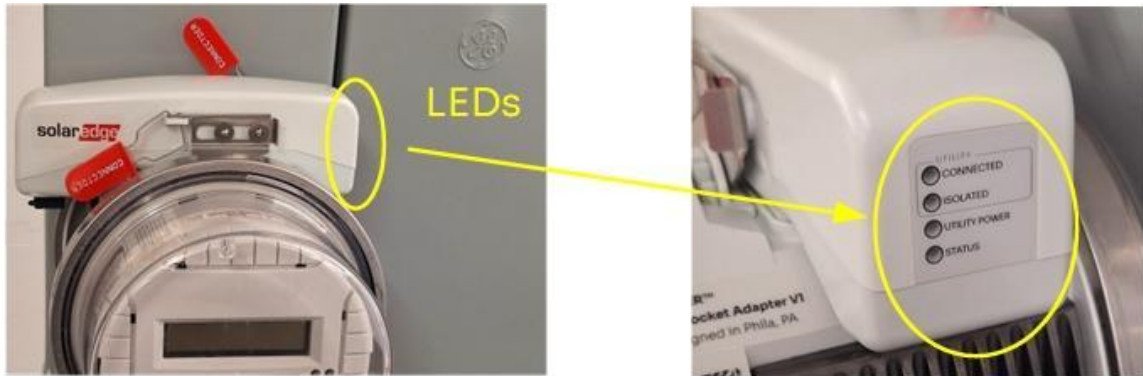

Figure 27. Normal Startup LED Status.



NOTE - if the STATUS LED is blinking red, either: 1) the Manual MID Override Switch cover on the bottom face of the IslandDER MSA Base is removed, 2) the cable to the SolarEdge Nexis BESS is disconnected, or 3) the Nexis BESS is de-energized. For more info, consult the LED Status Lights and Troubleshooting section.

27. Verify the Ethernet RJ-45 port is capped off with included dust cap to prevent entry of moisture, debris, etc. as shown in Figure 28.



Figure 28. Ethernet RJ-45 Port Capped Off. IslandDER MSA ready for connection to BESS.

**IslandDER MSA Installation Task Checklist:**

- ✓ IslandDER MSA Base and Connection Module installed.
- ✓ Lock rings installed.
- ✓ Tamper-prevention seals installed on Connection Module latches, lock rings, and meter socket cover.
- ✓ LEDs indicating normal status.
- ✓ Digital RJ-45 port capped off.

28. The IslandDER V1 MSA installation is complete. Refer to the instructions below to connect the Communications Cable to the SolarEdge Nexis BESS.

**REMOVING THE CONNECTION MODULE (IF NEEDED)**



NOTE - A Connection Module is included in the box with the MSA Base, but replacement Connection Modules may also be sold and serviced as an independent accessory. This enables the Connection Module to be REPLACED (if needed) without removing the MSA Base.

If there is a need to remove the Connection Module:

1. Cut and remove the utility tamper-prevention seals on the front and rear latches of the existing Connection Module.
2. Slide open the front and rear latches of the existing Connection Module.
3. Gently remove the existing Connection Module from the MSA Base. If being REPLACED as part of an approved RMA, ship it back to ConnectDER, as directed by Customer Support. If the MSA Base will be left without a Connection Module for long, cover the top of the MSA Base with an electrical insulation blanket to protect the pins. If the replacement Connection Module cannot be installed during the same service visit, measures must be taken to ensure no water ingress into the MSA base. The existing Connection Module may be temporarily reinstalled, or the MSA base must be temporarily removed.
4. Disassemble/loosen the Ethernet boot, and carefully unplug the Ethernet cable from the RJ-45 port.

## CONNECT COMMUNICATIONS CABLE TO SolarEdge Nexis BESS

### ITEMS REQUIRED TO CONNECT COMMUNICATIONS CABLE TO SolarEdge Nexis BESS



NOTE – The following items (provided by the installer) are required to connect the IslandDER MSA Communications Cable to the SolarEdge Nexis BESS.

Qty.	Item
1	Wire cutter, e.g., diagonal pliers.
1	Calibrated digital volt-ohmmeter or other suitable metering equipment,
1	Ethernet network cable connectivity tester.
1	Environmentally suitable Cat5e (or higher) cable.
1	RJ45 connector crimping tool if necessary for furnishing Ethernet cable
2	RJ45 connectors if needed for furnishing Ethernet cable
1 lot	Tools and materials to route and support the Communications Cable from the IslandDER MSA to the SolarEdge Nexis BESS in a professional and skillful manner, and to protect the cable from physical damage.
1 roll	Electrical tape.
1 lot	Additional tamper-prevention seals. Five are furnished with each unit to secure the Connection Module hasps, meter socket rings and cover.
1	A calibrated torque driver with a minimum range of 2 in. lbs.

- 1 #0 or #1 Philips screwdriver, or 5/32" flat blade screwdriver.
- 1 #0 or #1 Philips tip for a torque driver, or 5/32" flat blade tip for a torque driver.



WARNING – IslandDER MSA installation must be performed by qualified personnel only. Follow your employer’s requirements for personal protective equipment (PPE) and procedures.

## CONNECT THE COMMUNICATIONS CABLE TO THE SolarEdge Nexis BESS



NOTE – Follow the SolarEdge Nexis BESS installation instructions. Confirm the BESS is ready for connecting the Communications Cable before proceeding.

1. Use an environmentally suitable Cat5e (or higher) Ethernet cable. Ensure it is suitable for the environment to be installed, e.g., weatherproof, sunlight resistant, etc. A black CAT 6 cable suitable for indoor use is depicted in this document. Check cable integrity using Ethernet cable tester before connecting.
2. A generic weatherproof enclosure is shown representing the termination means for the BESS. Follow the SolarEdge Nexis BESS instructions to connect one end of the Ethernet cable into the BESS (shown here entering the enclosure with a weatherproof cord connector).
3. Route and support the Ethernet cable toward the IslandDER MSA in a professional and skillful manner that protects the cable from physical damage. Provide slack for a drip loop to prevent water from entering the BESS and the Connection Module. See Figure 29.



NOTE - Do not coil any excess slack around the meter or the MSA. Use appropriately sized and outdoor/UV rated cable clips.



Figure 29. Ethernet Cable.

4. Confirm that working clearances and equipment access comply with utility and AHJ requirements.
5. Unpack the Ethernet boot kit furnished with the MSA. Two split grommets are furnished to fit a variety of Ethernet cable diameters. See Figure 30.

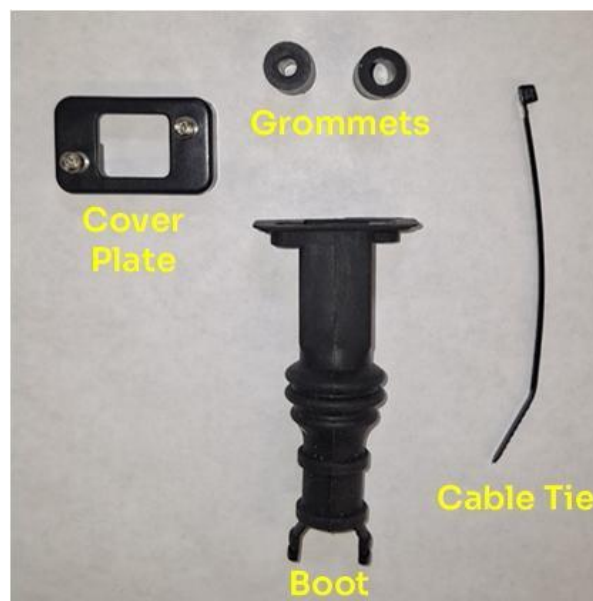

Figure 30. Ethernet Boot Kit Components.

6. Pull the boot through the cover plate as shown in Figure 31.

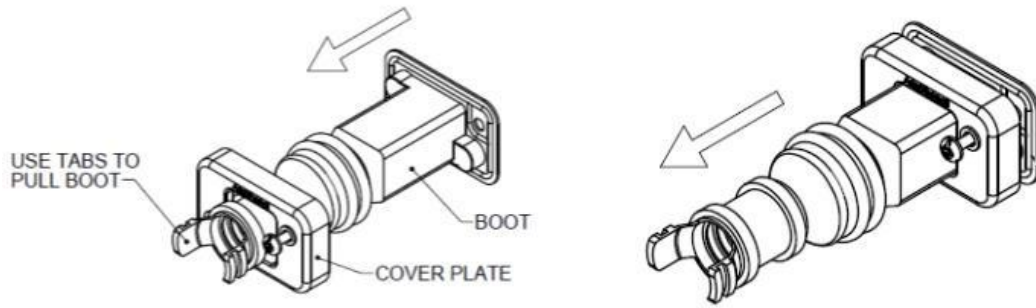

Figure 31. Pull Boot Through Cover Plate.

7. Insert the MSA end of the Ethernet cable through the boot and cover plate assembly. See Figure 32.

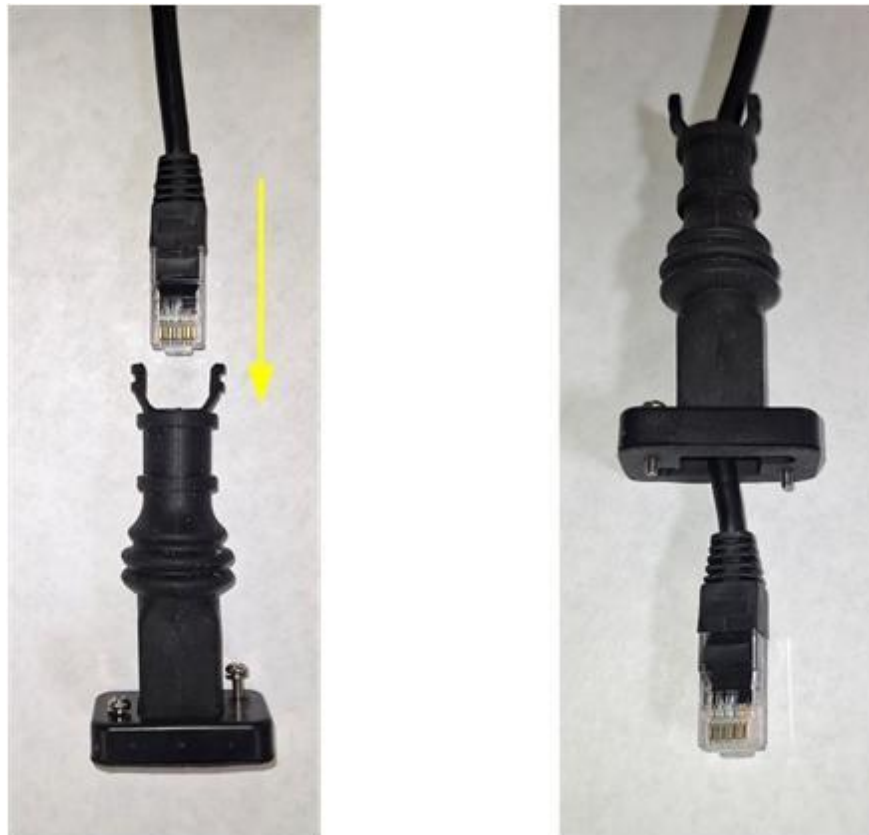

Figure 32. Ethernet Cable Through Boot and Cover Plate.

8. Remove the dust cap on the Connection Module RJ-45 port. See Figure 33.



Figure 33. Ethernet RJ-45 Port. Remove Dust Cap for Cable Connection.

9. Confirm the SolarEdge Nexus BESS is ready for connecting the Ethernet cable to the Connection Module RJ-45 port.
10. Mate the plug into the RJ-45 port on the Connection Module. See Figure 34.



Figure 34. Mate the Ethernet Cable to the Communications Module RJ-45 Port.

11. Slide the boot assembly against the Connection Module RJ-45 port. Carefully use either a #0 Philips, #1 Philips, or 5/32" flat blade driver to secure the cover plate

screws to the Connection Module, taking care not to overtighten. Torque to 2 in. lbs. See Figure 35.



*Figure 35. Torque Boot Assembly Screws to 2 in. lbs.*

12. Select the grommet that best fits the Ethernet cable diameter. Open the grommet along the split line and place it around the cable and slide it into position between the boot ribs. See Figure 36.

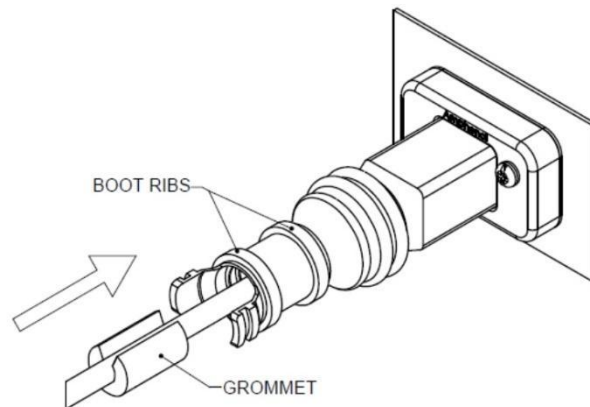

*Figure 36. Insert Grommet around Ethernet Cable and Slide into Place.*

13. Secure the cable tie around the middle of the boot ribs and tighten the boot around the grommet. See Figure 37.

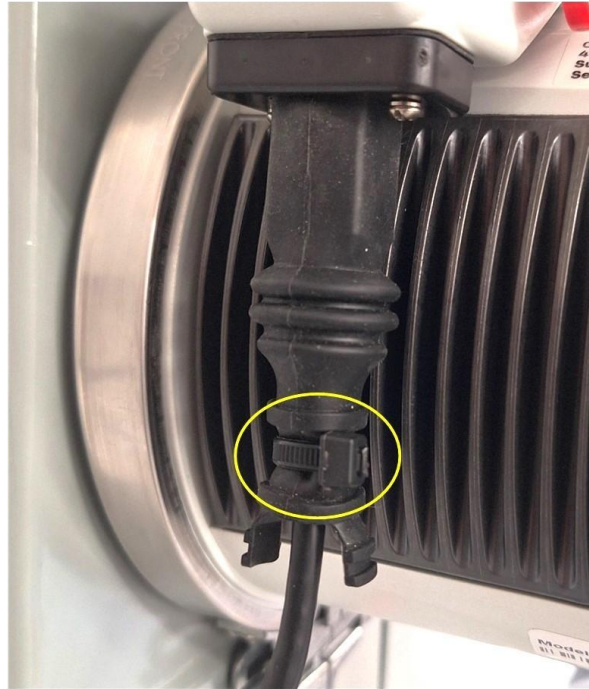

*Figure 37. Cable Tie Around Boot and Grommet.*

14. Check the LED status on the opposite end of the Connection Module from the Communications Cable. Confirm the 'Utility Connected' white light is on, and the 'Status' LED is solid green after blinking a few minutes. See Figure 38.

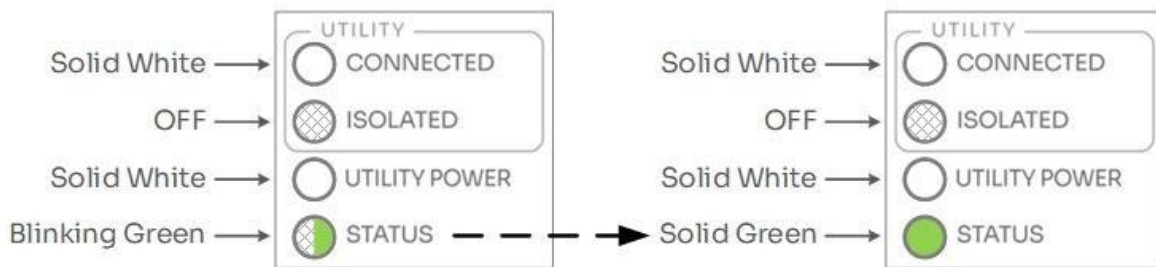
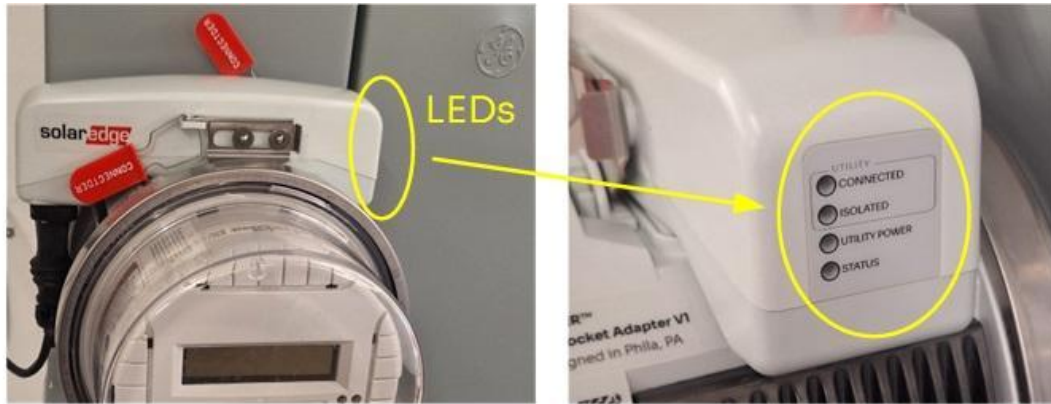

Figure 38. Normal Startup LED Status.



NOTE - if the STATUS LED is blinking red, either 1) the Manual MID Override Switch cover on the bottom face of the IslandDER MSA Base is removed, 2) the cable to the SolarEdge Nexis BESS is disconnected, or 3) the Nexis Bess is de-energized. For more info, consult the LED Status Lights and Troubleshooting section.

15. Confirm the Ethernet cable is routed and supported in a professional and skillful manner with drip loops to prevent water entry to the BESS and Connection Module. See Figure 39.



*Figure 39. IslandDER Digital MSA. Ethernet cable routing towards the BESS.*

16. Commission the IslandDER MSA using the SolarEdge Go app according to the SolarEdge Nexis BESS installation guide.

## LED STATUS LIGHTS & TROUBLESHOOTING

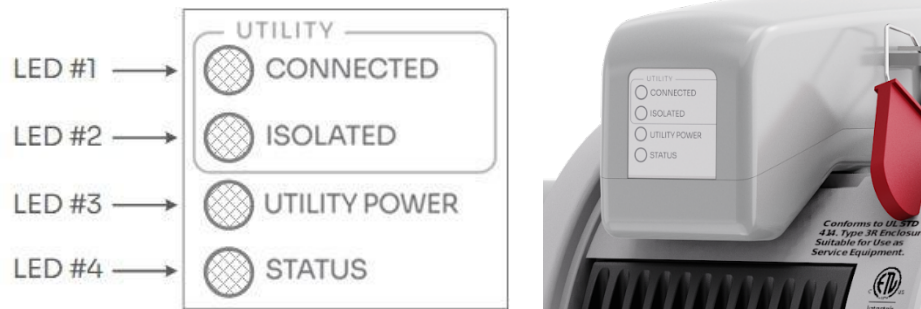

Table 1 below outlines the Individual LED status indicators.

	LED ACTIVITY	LED LABEL	FUNCTION
1	Solid White	UTILITY CONNECTED	MID Relay Closed. Home is connected to the utility.
2	Solid Blue	UTILITY ISOLATED	MID Relay Open. Home is isolated from the utility.
3	Solid White	UTILITY POWER	Utility power is present.
4	Blinking Green	STATUS	MID relay is not ready to operate. (charging in progress). Wait a few mins until Solid Green.
	Solid Green		MID relay is ready to operate, no MSA fault. Tool Access Cover for Manual MID Operation is in place.
	Blinking Red		Either: a) Manual MID Override Switch cover on the bottom face of the MSA Base has been removed, b) The cable to the Nexis BESS is disconnected, OR c) The Nexis BESS is de-energized.
	Solid Red		MSA fault. MSA must be replaced.

Table 1. IslandDER MSA LED Behavior.

Table 2 below (multiple pages) outlines the grouped LED status indicators.



NOTE –This is for the MSA only. It does not verify the status of the SolarEdge Nexis BESS.

LED ARRAY	MSA STATUS & CORRECTIVE ACTION, IF ANY
	<p>No power from the utility, AND No power from alternate source(s).</p> <p>Verify BESS status.</p>
	<p>MID relay is closed. Utility power present. MID relay is not ready to operate (charging in progress).</p> <p><b>Normal behavior upon initial startup.</b></p> <p>Wait up to 2 minutes until the MID capacitors are charged; blinking green will change to solid green.</p> <p>If green LED fails to turn solid, contact Support.</p>
	<p>MID relay is closed. Utility power present. MID relay is ready to actuate if necessary.</p> <p><b>Indicates normal on-grid system operation.</b></p>

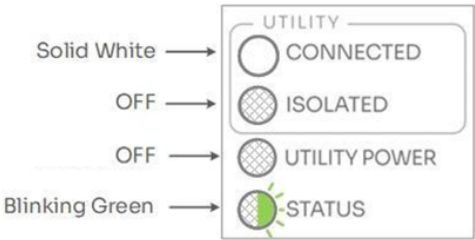
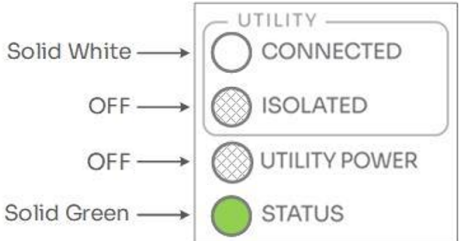
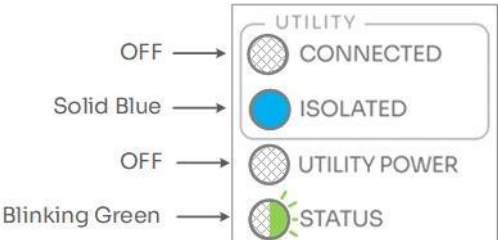
LED ARRAY	MSA STATUS & CORRECTIVE ACTION, IF ANY
 <p>Solid White →</p> <p>OFF →</p> <p>OFF →</p> <p>Blinking Green →</p>	<p>MID relay is closed. Utility power is not present. MID relay is not ready to operate (charging in progress).</p> <p>Check grid status. Wait up to 2 minutes until the MID capacitors are charged; blinking green will change to solid green.</p> <p>If green LED fails to turn solid, contact Support.</p>
 <p>Solid White →</p> <p>OFF →</p> <p>OFF →</p> <p>Solid Green →</p>	<p>MID relay is closed. Utility power is not present. MID relay is ready to actuate if necessary.</p> <p>SolarEdge Nexis BESS may command the MID to open (isolate from the utility) and connect a backup power source at its discretion.</p>
 <p>OFF →</p> <p>Solid Blue →</p> <p>OFF →</p> <p>Blinking Green →</p>	<p>MID relay is open. Utility power is not present. MID relay is not ready to operate (charging in progress).</p> <p>Wait up to 2 minutes until the MID capacitors are charged; blinking green will change to solid green.</p> <p>If green LED fails to turn solid, contact Support. NOTE: if the home is isolated (MID open) but there is no backup power available from the Nexis BESS, or it is showing a fault, contact SolarEdge Support.</p>

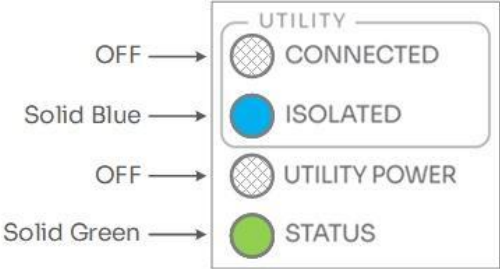
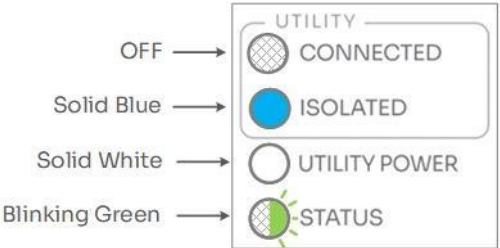
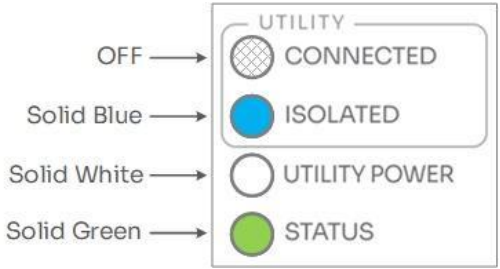
LED ARRAY	MSA STATUS & CORRECTIVE ACTION, IF ANY
	<p>MID relay is open. Utility power is not present. MID relay is ready to actuate if necessary.</p> <p>Indicates off-grid system operation.</p> <p>Wait for utility power to be restored. The SolarEdge Nexis BESS will determine when to close the MID after utility power is restored.</p> <p>NOTE: if the home is isolated (MID open) but there is no backup power available from the Nexis BESS, or it is showing a fault, contact SolarEdge Support.</p>
	<p>MID relay is open. Utility power present. MID relay is not ready to operate (charging in progress).</p> <p>Typical after a prolonged utility outage. The SolarEdge Nexis BESS is preparing the MID for readiness to transfer to utility power.</p> <p>Wait up to 2 minutes until the MID capacitors are charged; blinking green will change to solid green.</p> <p>If green LED fails to turn solid, contact Support. NOTE: if the home is isolated (MID open) but there is no backup power available from the Nexis BESS, or it is showing a fault, contact SolarEdge Support.</p>
	<p>MID relay is open. Utility power present. MSA OK. MID relay is ready to actuate if necessary. E-stop loop is closed.</p> <p>Indicates off-grid system operation. Utility power, if lost, has been restored. The BESS will command the MID to close at its discretion to reconnect to the utility.</p> <p>If power is not restored to the house, contact Support. NOTE: if the home is isolated (MID open) but there is no backup power available from the Nexis BESS, or it is showing a fault, contact SolarEdge Support.</p>

LED ARRAY	MSA STATUS & CORRECTIVE ACTION, IF ANY
	<p>Regardless of the other LED lights, a blinking red status indicates either:</p> <ol style="list-style-type: none"> <li>The Manual MID Override Switch cover on the bottom face of the MSA Base has been removed,</li> <li>The cable to the SolarEdge Nexis BESS is disconnected, OR</li> <li>The Nexis BESS is de-energized.</li> </ol> <p><b>Check: a) the Manual MID Override Switch cover on the bottom face of the MSA Base and replace if removed, b) that the cable connecting IslandDER to the Nexis BESS is connected on both ends, and c) if the Nexis BESS is energized.</b></p> <p><b>Only qualified personnel should service the MSA.</b></p>
	<p>Any LED status combination with a solid red light.</p> <p><b>Non-recoverable fault. The MSA must be replaced. Contact Support and RMA the unit.</b></p> <p><b>When replacing the MSA, use proper PPE and uninstall the existing unit in reverse order, taking care to follow any serving utility and AHJ requirements for MSA removal / install.</b></p>

Table 2. Interpreting LED Status & Troubleshooting the IslandDER MSA.

Contact SolarEdge ([www.solaredge.com/us/contact-us](http://www.solaredge.com/us/contact-us)) for initial technical support regarding the installation, commissioning, or servicing of the IslandDER MSA. Always adhere to the requirements of the serving electric utility and AHJ. For additional questions or specialized hardware assistance, contact ConnectDER Support at [www.connectder.com/contact](http://www.connectder.com/contact)

## MANUAL MID OVERRIDE PROCEDURE

**WARNING** – The MID override procedure must be performed by qualified personnel ONLY. Unqualified persons attempting to install or service the IslandDER MSA could result in damage, serious injury, or death.

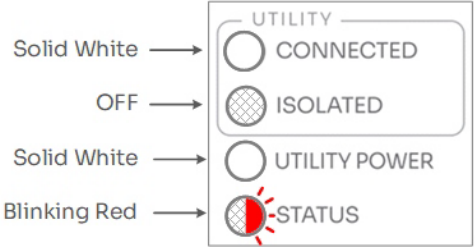
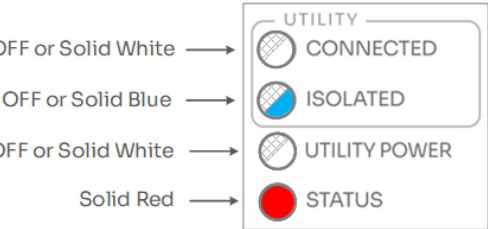

All power sources must be disconnected prior to operating this switch. Follow your employer’s requirements for personal protective equipment (PPE) and procedures.

When utility power is lost, the SolarEdge Nexis BESS commands the IslandDER MSA to open the MID. Opening the MID isolates (“islands”) the premises from the utility, thereby preventing inadvertent backfeeding to the grid, and safely facilitating backup power from a SolarEdge Nexis BESS.

The SolarEdge Nexis BESS can provide power to the premises for as long as its alternate source is available. If utility power is lost for an extended period of time and the SolarEdge Nexis BESS is depleted (unable to supply 12V power to the IslandDER MSA), the entire system including the premises is powered off.

When utility power is restored, the IslandDER MSA powers on and updates its status to the SolarEdge Nexis BESS. In the unlikely event the Nexis BESS fails to signal the IslandDER to re-close the MID, the IslandDER MSA is equipped with a tool to manually close the MID, restoring utility power to the premises.

### MANUALLY CLOSE THE MID

**WARNING** – The MID override procedure must be performed by qualified personnel ONLY. Unqualified persons attempting to install or service the IslandDER MSA could result in damage, serious injury, or death.



All power sources must be disconnected prior to operating this switch. Follow your employer’s requirements for personal protective equipment (PPE) and procedures.

Refer to the service procedures of the respective alternative energy source.

1. Deenergize the SolarEdge Nexis BESS and all connected energy sources so that the BESS is Off or in a Standby mode. See SolarEdge Nexis BESS documentation for instructions to deenergize the BESS.
2. The Manual MID Override Switch cover is attached to the bottom of the IslandDER MSA Base, and serves as both the switch cover and actuation tool. It is the T-shaped device circled in Figure 40 below.



Please note the orientation of the cover since it must be re-attached in the same position. The SolarEdge Nexis BESS may not resume normal operation if the cover is not replaced properly. Please ensure 3-4 inches of clearance for operation.

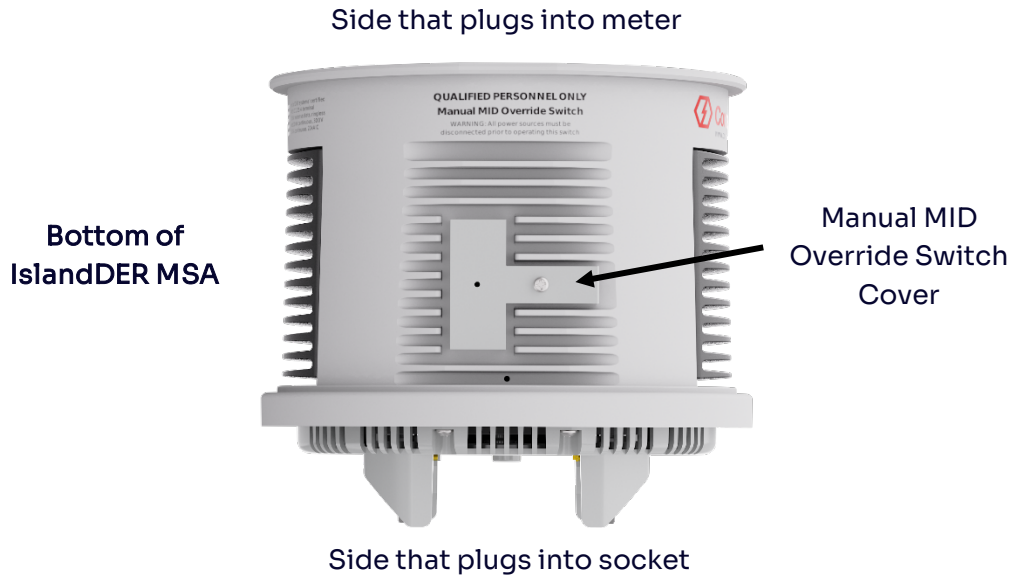

Figure 40. Manual MID Override Switch cover on the Bottom of IslandDER MSA.

3. Remove the Manual MID Override Switch cover using a #0 or #1 Philips screwdriver to reveal the square port and the Manual MID Override Switch. See Figure 41.

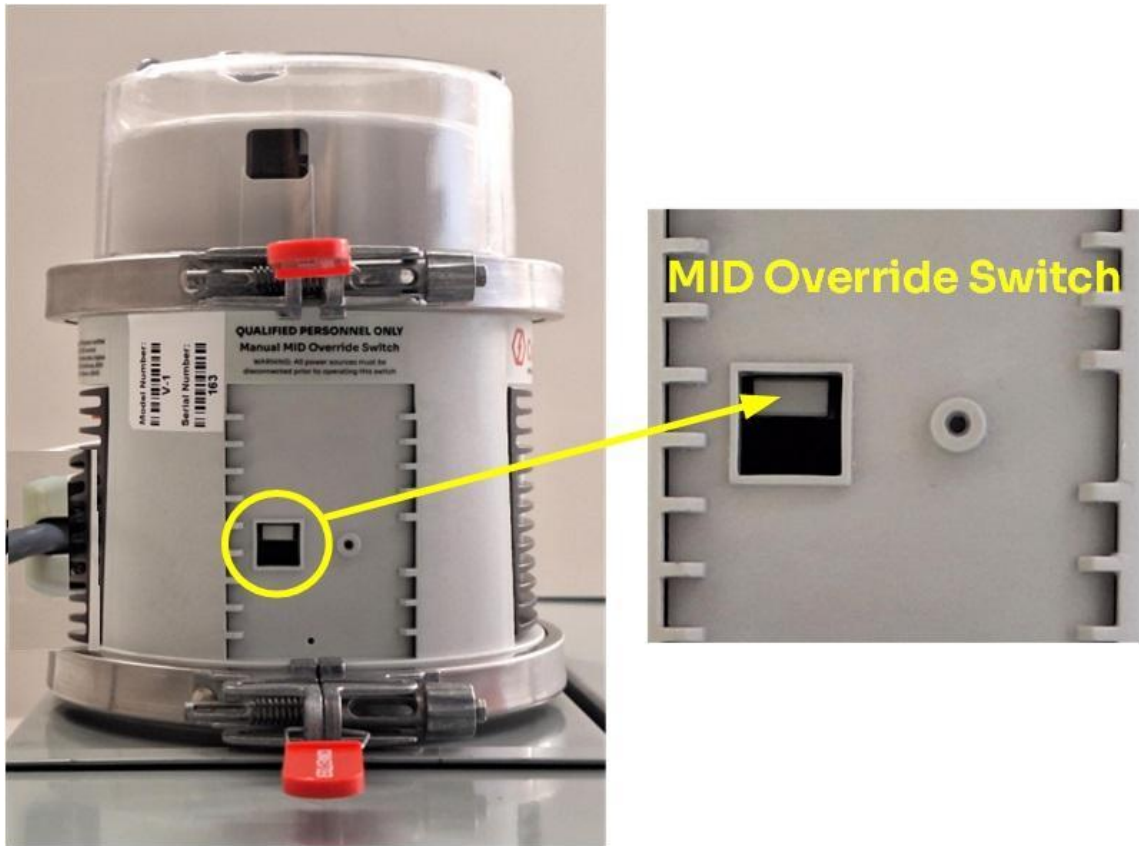
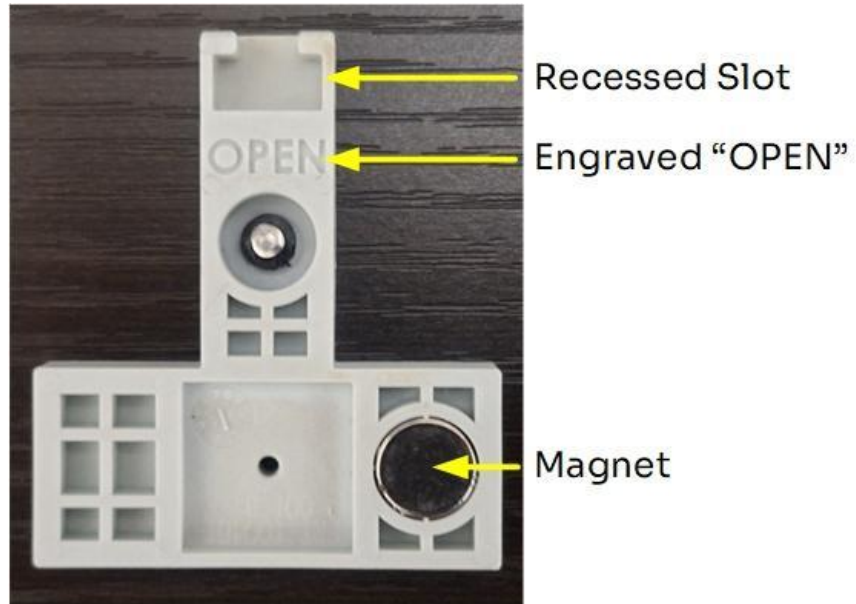

Figure 41. Manual MID Override Switch.

4. Confirm the Status LED on the Connection Module is OFF or Blinking Red, and the Nexis BESS is off or in standby mode. A green LED following the removal of the Manual MID Override Switch cover indicates an MSA failure; the unit must be replaced.
5. Turn over the t-shaped cover and note its features as shown in Figure 42 below. The cover functions as a tool to actuate the MID Override Switch.



*Figure 42. Features of the Manual MID Override Switch Cover. The cover also functions as a tool to activate the Manual MID Override Switch.*

6. Refer to Figure 43 below.
  - a. Position the cover (with its recessed slot facing forward) toward the rear of the square opening (toward the meter socket).
  - b. Move the cover upward aligning the bottom of the slot with the MID Override Switch.
  - c. Move the cover forward until it latches onto the MID Override Switch.
  - d. Push cover upward again to close the MID Override Switch. The relay will audibly 'click' as it closes, and the engraved "OPEN" on the cover will disappear from view.

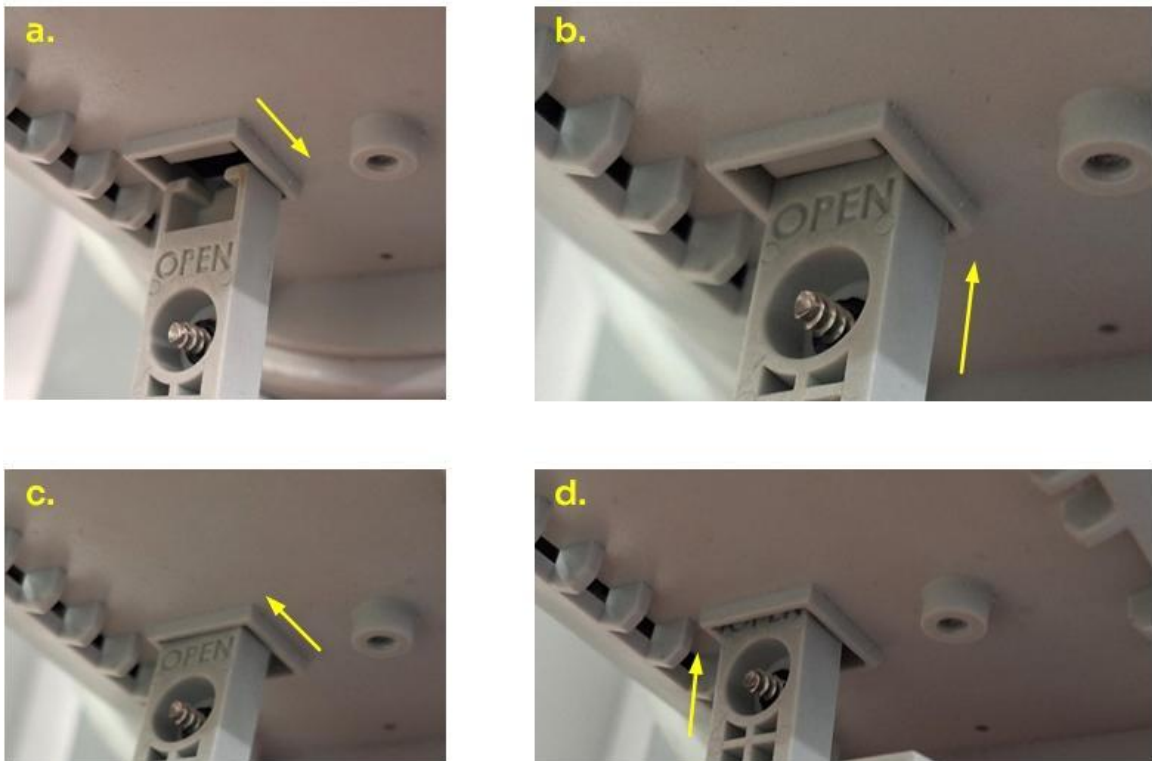

Figure 43. Manual MID Override Switch Closure Procedure.

7. Utility power is now restored to the premises. If the MID needs to be manually opened, pull the cover downward until the word “OPEN” appears. Note: if upon closing the MID relay it is observed that the MID relay immediately is forced back open, contact Support.
8. Remove the cover from the MID Override Switch.
9. Re-attach the cover to its original position using a #0 or #1 Philips screwdriver. Be careful not to overtighten. Torque to 5 in-lbs. **Note that if the cover is not reinstalled, the SolarEdge Nexis BESS may not resume normal operation.**
10. Check the LED status on the opposite end of the Connection Module from the Communications Cable. Confirm the ‘Utility Connected’ white light is on, and the ‘Status’ LED is no longer blinking red. It should be solid green after blinking a few minutes. See Figure 44.

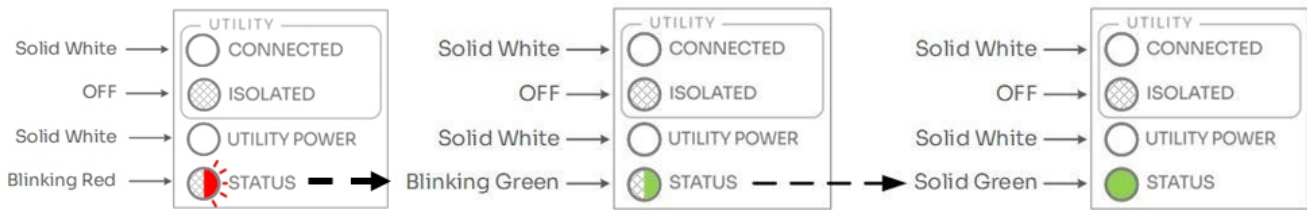

Figure 44. LED Sequence as the Manual MID Override Switch cover is replaced. While the cover is missing, the Status LED blinks red. Once it is replaced, the Status LED blinks green. After a few mins, it turns solid green.

11. Follow the SolarEdge Nexis instructions to safely restore the BESS to normal operational status.



NOTE - if the STATUS LED is blinking red, either: 1) the Manual MID Override Switch cover on the bottom face of the IslandDER MSA Base has not been replaced correctly, 2) the cable to the SolarEdge Nexis BESS is disconnected, or 3) Nexis BESS is de-energized. Consult the LED Status Lights and Troubleshooting section.

## CALIFORNIA IOU MSA PROCESS GUIDELINES

Investor-owned utilities in California and in some other states install meter socket adapters themselves and require the installation contractor and homeowner to follow strict guidelines. Check in advance for their specific process to avoid delays and payments for multiple truck rolls.

The contractor submits a request for the MSA to be installed via the utility’s project portal and pays a fee. There is normally a 10-day or similar work window for the utility to complete the request.

Adhere to applicable utility clearance requirements from gas meters, etc. **The utility may require the balance of the DER (e.g., solar, battery) system to be completed first:**

- a) **The Ethernet Cable should be connected to the SolarEdge Nexis BESS AND to the IslandDER Connection Module including the Ethernet boot.**
- b) **The Connection Module should be fully seated on the MSA Base, with both the front and rear latches closed and tamper-prevention seals installed to keep them in place.**

**The complete MSA assembly must be left onsite and sealed in a high-visibility, weatherproof bag** near the existing meter with the Communications Cable connected. Tie the bag securely to a nearby conduit or other means suitable to the utility, and ensure the bag is fully closed/sealed in a manner to prevent water ingress. See Figure 45.



**NOTE – IF THIS PROCESS IS NOT FOLLOWED PROPERLY AND/OR THE BAG IS DAMAGED, THE UTILITY MAY REJECT THE MSA INSTALLATION AND CHARGE ANOTHER TRUCK ROLL FEE TO RETURN. PLAN FOR UTILITY PERSONNEL TO ONLY PLUG IN THE COMPLETE MSA ASSEMBLY AND NOTHING MORE.**



*Figure 45. DER System Completed, Ready for MSA Installation.*

# APPENDIX

## Reference 1 – ETL Authorization to Mark



**Total Quality. Assured.**

### AUTHORIZATION TO MARK

This authorizes the application of the Certification Mark(s) shown below to the model(s) described in the Product(s) Covered section when made in accordance with the conditions set forth in the Certification Agreement and Listing Report. This authorization also applies to multiple listee model(s) identified on the correlation page of the Listing Report.

This document is the property of Intertek Testing Services and is not transferable. The certification mark(s) may be applied only at the location of the Party Authorized To Apply Mark.

<b>Applicant:</b> ConnectDER, Inc	<b>Manufacturer:</b> ConnectDER, Inc
<b>Address:</b> 2037 Washington Ave. Philadelphia, PA19146	<b>Address:</b> 2037 Washington Ave. Philadelphia, PA19146
<b>Country:</b> USA	<b>Country:</b> USA
<b>Party Authorized To Apply Mark:</b> Same as Manufacturer	
<b>Report Issuing Office:</b> Intertek Testing Services NA, Inc., Plano, TX	
<b>Control Number:</b> <u>5028888</u>	<b>Authorized by:</b> <u><i>Matthew Snyder</i></u> for   Matthew Snyder, Certification Manager



This document supersedes all previous Authorizations to Mark for the noted Report Number.

This Authorization to Mark is for the exclusive use of Intertek's Client and is provided pursuant to the Certification agreement between Intertek and its Client. Intertek's responsibility and liability are limited to the terms and conditions of the agreement. Intertek assumes no liability to any party, other than to the Client in accordance with the agreement, for any loss, expense or damage occasioned by the use of this Authorization to Mark. Only the Client is authorized to permit copying or distribution of this Authorization to Mark and then only in its entirety. Use of Intertek's Certification mark is restricted to the conditions laid out in the agreement and in this Authorization to Mark. Any further use of the Intertek name for the sale or advertisement of the tested material, product or service must first be approved in writing by Intertek. Initial Factory Assessments and Follow up Services are for the purpose of assuring appropriate usage of the Certification mark in accordance with the agreement, they are not for the purposes of production quality control and do not relieve the Client of their obligations in this respect.

Intertek Testing Services NA Inc.  
545 East Algonquin Road, Arlington Heights, IL 60005  
Telephone 800-345-3851 or 847-439-5667 Fax 312-233-1672

<b>Standard(s):</b>	Meter Sockets [UL 414:2016Ed.9+R.01Mar2024]
<b>Product:</b>	Meter-Mounting Devices (R2010) [CSA C22.2#115:1989 Ed.5+G1;G2;G3]
<b>Brand Name:</b>	IslandDER
<b>Models:</b>	V 1 A 8, V 1 A X, V 1 D, V 1 D SE, V 1 D X

ATM for Report 105940363DAL-001

ATM Issued: 25-Apr-2025  
ED 16.3.15 (1-Jul-2022) Mandatory

## Reference 2 – Digital IslandDER MSA Model Number

Form 2S, 12S METER TYPES			
IslandDER Product	MSA Base Model #	MSA Connection Module Model #	Combined Model Number (listed on the package)
V1, Digital, SolarEdge Suffix	V-1	D-SE	V-1-D-SE

## Reference 3 – IslandDER MSA Specifications

MECHANICAL SPECIFICATIONS		COMMUNICATIONS	
ENCLOSURE RATING	NEMA 3R	TYPE	Discrete sensing, control, status, and 12V power signals
ENCLOSURE TYPE	Injection molded polycarbonate, UL 94 5VA flame rating	CABLE	Field-installed, Outdoor/UV rated Ethernet cable
THERMAL MANAGEMENT	Passive Cooling, Heat Sinks	CONNECTION	Field-wired from Connection Module to SolarEdge Nexis BESS, Pluggable, Weathertight RJ45 Connection with sealing boot, Reversible at top of MSA.
OPTIONAL NEUTRAL CONNECTION	Wired to Meter Socket or 5 <sup>th</sup> Stab Options	POWER	12V DC bus to/from SolarEdge Nexis BESS, Max 5W power supply available to SolarEdge Nexis BESS from grid side of MID (load side of meter)
DIMENSIONS (H X W X D)	(W) 7.6" x (H) 7.8" x (D) 4.9"	MSA CURRENT SENSING	ANSI 0.2 Accuracy Class CTs for Revenue Grade Sensing,
WEIGHT	5.65 lbs / 2.56 kg (with Connection Module)	MSA VOLTAGE SENSING	Line and Load (of MID) - 0.4% Accuracy at Ambient, 1% across Temperature Range
SHIPPING WEIGHT	7.3 lbs (3.31kg)	MID CONTROL	Discrete open/close signals with 1ms input noise rejection, Actuation time < 15ms
MOUNTING SYSTEM	Blade interface with 4-jaw or 5-jaw meter socket	MSA STATUS	Discrete signals for: MID open/close status, manual MID override interlock, MID ready, grid power present, MSA fault
ELECTRIC METER COMPATIBILITY	Type 2S, 12S	INTERNAL TEMPERATURE SENSING	-58°F to 302°F (-50°C TO 150°C)
METER SOCKET COMPATIBILITY	Ringless, Ring-type, Lever, Horn Bypass	WHOLE PRODUCT SENSING ACCURACY	Current < 1% at ambient, Voltage < 1% at ambient, <1.6% across temperature range
MANUAL MID OVERRIDE	Externally Accessible Switch, Protected by (Dry Contact) Interlocked Tool-Access Cover		
RATINGS			
VOLTAGE	208V, 240V	EMISSIONS	FCC CFR Part 15 Class B, ANSI C12 / IEC 61000
MAX CONTINUOUS CURRENT	200A	ETL FILE NUMBER	5028888
SHORT CIRCUIT RATING	22K AIC*	AMBIENT AIR OPERATING TEMPERATURE RANGE	-22°F to 149°F (30°C TO 65°C)
MID RATED CYCLES	10,000	AMBIENT AIR STORAGE TEMPERATURE RANGE	-40°F to 176°F (-40°C TO 80°C)
APPLICABLE SAFETY STANDARDS	UL 414, SA, SB, SC – Meter Sockets, UL 1741 / UL 3141 / UL 9741 System Ready		
* Rating independent of any external load side overcurrent devices			

## Reference 4 – IslandDER V1 MSA Product Labels

IslandDER Product ID Label  
1.5" x 0.6"



French Translation:

**IslandDER™**  
**Adapteur de socle de compteur d'électricité V1**  
**% Conçu à Philadelphie, PA**

IslandDER UL Standard Label  
1.5" x 0.6"

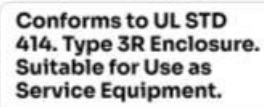

French Translation:

**Conforme au standard UL 414.**  
**Boîtier de type 3R. Convient à**  
**une utilisation comme**  
**équipement de service.**

IslandDER ConnectDER Logo Label  
4" x 0.7"



IslandDER Intertek Label  
4" x 0.7"

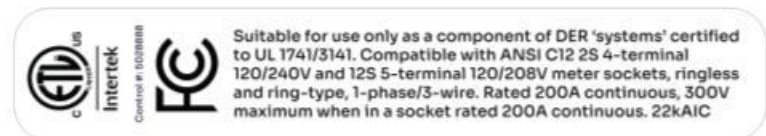

French Translation:

**Convient uniquement à une utilisation comme composante d'un système d'énergie décentralisée (DER) certifié au standard UL 1741/3141. Compatible avec des socles de compteur d'électricité ANSI C12 à 4 bornes, forme 2S, 120V/240V, et à 5 bornes, forme 12S, 120V/208V, sans anneau et de type anneau, monophasées, 3 fils. Spécifié jusqu'à 200 ampères nominal en service continu, 300 V maximum, lorsqu'il est utilisé avec un socle de compteur spécifié jusqu'à 200 ampères nominal en service continu. 22kAIC**

IslandDER Base Serial Number Label  
1.5" x 1.5"

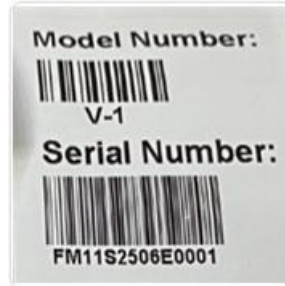

IslandDER Partner Logo Label  
2" x 0.75"



IslandDER MID Override Switch Label  
2.25" x 0.8"

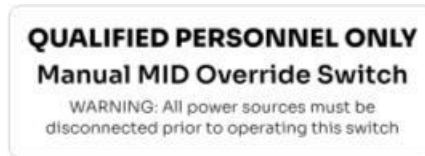

French Translation:



IslandDER Connection Module Status Label  
1.06" x 1.13"

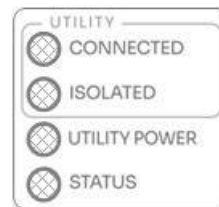

French Translation:

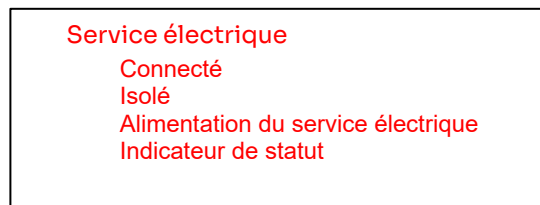

IslandDER Short-Circuit Current Rating Label  
3.5" x 1"

**Short-Circuit Current Rating:**  
22,000 RMS symmetrical amperes,  
300V maximum. Watthour meter not  
included in short-circuit current rating.

French Translation:

**Courant Nominal de Court-Circuit:**  
Courant RMS symétrique de 22,000 ampères,  
300V maximum. Compteur d'électricité n'est pas  
inclus dans le courant de court-circuit nominal.

Optional Neutral Lug Label  
1.8" x 1"

**Neutral connection not  
required. If used, torque  
values: 45 in-lbs (#4-6  
AWG) 40 in-lbs (#8 AWG)  
35 in-lbs (10-12 AWG)**

French Translation:

**Connection au neutre non requis. Si  
utilisé, tension de serrage: 5.2 Nm (#4-6  
AWG), 4.5 Nm (#8 AWG), 4 Nm (#10-12  
AWG)**

IslandDER Connection Module  
Model & Serial Number Label  
1" x 1"

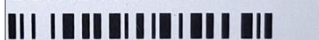
**Model Number:**  
  
**D-SE**  
**Serial Number:**  
  
**163**

Shipping Box Model Number Label  
4" x 2"

  
**Model Number:**   
**MSA Base** V-1-D-SE  
**Serial Number:**   
XDR6X2612D0001  
**CM Serial Number:**   
XDR7X2612D0001

IslandDER Accessory Bag Label

4" x 6"



## ConnectDER IslandDER Meter Socket Adapter V1

Scan the QR code to access the product installation manual. Read the manual in its entirety before installation.

### Important Installation Reminders

- Device must only be installed by qualified and competent personnel.
- Utility meters should only be removed with utility approval and best practices.
- Safety First! Always use appropriate PPE and follow NFPA 70E electrical safety best practices.
- Open all service disconnects and all other potential energy sources to de-energize power to the premises before installation. Installation should never occur under load.
- Install the provided tamper-resistant seals to secure pluggable connection module hasps, locking ring(s), and meter socket cover.
- Device must only be installed right side up, with the pluggable connection module on the TOP.
- The device has no serviceable parts, including the communications cable. Do NOT disassemble or modify under any circumstances.
- The device should only be installed in combination with a supported UL 1741/3141/9741 system that has been specifically evaluated for use with IslandDER. Connect the communications cable to IslandDER and 3rd party equipment per both the IslandDER and 3rd party installation instructions / manuals.
- Refer to both the IslandDER and 3rd party equipment instructions/manuals for commissioning, operations and service procedures.
- If installing in a 5-terminal socket and with a form 2S or 12S meter, install the provided 5th stab to the back of the MSA as specified in the installation instructions/manual.
- For use with form 2S and 12S, ring and ringless meter sockets
- MID Override Switch should ONLY be operated by qualified/competent professionals per the IslandDER installation manual, and only after all connected power sources have been deenergized.

Questions? Contact [support@connectder.com](mailto:support@connectder.com)



NOTE - This model of IslandDER (V-1-D-SE) can ONLY be used with approved SolarEdge Nexis BESS equipment that has been NRTL listed for use as a complete system.



## FCC REGULATORY STATEMENT

This device complies with part 15 of the FCC Rules. Operation is subject to the following two conditions: (1) This device may not cause harmful interference, and (2) this device must accept any interference received, including interference that may cause undesired operation.

## CALIFORNIA PROP 65 WARNING



WARNING: This product can expose you to chemicals including acrylonitrile, which is known to the State of California to cause cancer and birth defects or other reproductive harm. For more information go to [www.P65Warnings.ca.gov](http://www.P65Warnings.ca.gov)

## DISCLAIMER

The information presented in this document represents ConnectDER's understanding of standards / test procedures and is provided for informational purposes. ConnectDER makes no representation as to the accuracy, completeness, suitability, or validity of the information. ConnectDER will not be liable for any errors, omissions, losses, injuries, or damages arising from the use of this information.

For the official views of Intertek, consult the appropriate standard, or contact Intertek directly regarding the ConnectDER IslandDER MSA, Intertek ETL File Number 5028888.