

ConnectDER Solar Meter Adapter Installation Manual - Version 5 (V5.1)



ConnectDER, Inc.

2037 Washington Ave.
Philadelphia, PA 19146

support@ConnectDER.com

REVISION HISTORY	3
SYMBOLS USED IN THIS MANUAL	4
INTRODUCTION	4
SOLAR METER ADAPTER FEATURES	6
WHAT'S NEW FOR V5.1	6
WIRING SCHEMATICS	7
BOX CONTENTS	9
INSTALLATION PREPARATION	10
INSTALLATION PROCEDURE	17
INTERCONNECT THE PV/DER WIRING	37
APPENDIX – SOLAR PV INTERCONNECTION WIRING EXAMPLE	45
SOLAR METER ADAPTER MODEL NUMBERS	46
SOLAR METER ADAPTER SPECIFICATIONS.....	47
CONTACT	48

REVISION HISTORY

Revision:	1.0	Date of Issue:	07/25/2023
Revision Comments:	Initial Release		
Author/Title:	Al Iaconangelo/Customer Implementation and Support Manager Dan Lasley/Electrical Engineer, Manager		
Key Reviewers:	Khanti Munro, Sr. Product Manager		
	Jon Knauer, VP Strategy and Business Development		
Approved By:	Al Iaconangelo/Customer Implementation and Support Manager		

SYMBOLS USED IN THIS MANUAL



WARNING

Designates information highlighting the risk of death, serious injury, or damage to property.



NOTE

Designates helpful information.

INTRODUCTION



NOTE - Version 1.0 of this document supersedes all previous versions. It is the responsibility of the party installing, replacing, and/or servicing the Solar Meter Adapter (the “installer”) to obtain and follow the most current installation document.

The ConnectDER™ Solar Meter Adapter is a UL Listed device that enables rapid interconnection of grid-ready distributed energy resources (DERs). It creates a safe, standardized, low-cost alternative to traditional wiring methods.

Underwriters Laboratories, Inc. (UL) grants its listing after verifying that products meet a high level of safety and quality, and conform to numerous codes and standards, one of which is the most current edition (**2023** edition for the V5 Solar Meter Adapter) of the National Electrical Code (NEC).

The Solar Meter Adapter operates in parallel with the utility grid. It is approved for use with interconnected electric power production sources in accordance with Article 705 of the NEC such as Listed grid-interactive photovoltaic (PV) systems where the inverter(s) meets UL 1741 requirements.

The installer assumes all responsibility and risk associated with the safe and intended use of the Solar Meter Adapter as expressed in the current installation document. Any deviation from the methods or applications in this manual will violate the product’s UL listing, NEC Article 110.3(B), and void the product warranty.

Contact ConnectDER, Inc. at support@connectder.com for the most current document and technical support before installing, replacing, and/or servicing the Solar Meter Adapter. Always follow utility and Authority Having Jurisdiction (AHJ) requirements.

Please read these instructions in their entirety before installing a Solar Meter Adapter.



WARNING - The ConnectDER Solar Meter Adapter contains live parts capable of causing death, injury, or damage to property.

Installation and servicing of the Solar Meter Adapter, all associated wiring and interconnections must be performed only by qualified personnel. Article 100 in the NEC defines a qualified person as *one who has the skills and knowledge related to the construction and operation of the electrical equipment and installations and has received safety training to recognize and avoid the hazards involved.*

Turn off the power supply and all other potential electricity sources before installing or servicing the Solar Meter Adapter. The graphics in this document depict **de-energized** equipment.

Use a calibrated voltmeter to confirm conductive parts are de-energized before touching. Use factory-insulated tools.

Do not alter the Solar Meter Adapter, or any other equipment or conductor in a manner that voids its listing or warranty. Do not attempt to replace the integrated DER circuit breaker or modify any other components.

ConnectDER recommends practicing the installation and wiring of the Solar Meter Adapter using de-energized equipment before proceeding with field installations.



WARNING - The Solar Meter Adapter is permitted to interconnect a parallel source to the supply side of the main service disconnecting means. The Solar Meter Adapter shall not interconnect electric vehicle chargers, batteries, or other loads. The 180-amp combined utility and DER rating is permitted only when the DER is an input source to the Solar Meter Adapter circuit breaker.

Loads connected to the DER breaker must be limited to the minimal current that inverter(s) require to start, commission, and monitor a PV/DER system.

SOLAR METER ADAPTER FEATURES

- Enables rapid connectivity for PV systems and other DERs.
- Quick-connect and quick-release weatherproof junction box for field wiring.
- Readily accessible circuit breaker for overcurrent protection and AC DER disconnect.
- Lockout/tagout capability for safety and security.
- Compatible with ringless, ring type, and lever bypass meter sockets*, form 2S, rated 200 amps maximum.



WARNING - *For lever bypass meter sockets, ConnectDER recommends:

- Locking out alternate/backup sources of power.
- Removing power from the premises loads.
- Actuating the lever bypass to facilitate meter removal.
- Removing the meter.
- Positioning the lever bypass to de-energize the load-side meter socket jaws.

This is covered again in the [INSTALLATION PROCEDURE](#).

WHAT'S NEW FOR V5.1

- Meter form 2S only, 120/240v.

WIRING SCHEMATICS

Figure 1 – Power Wiring Schematic

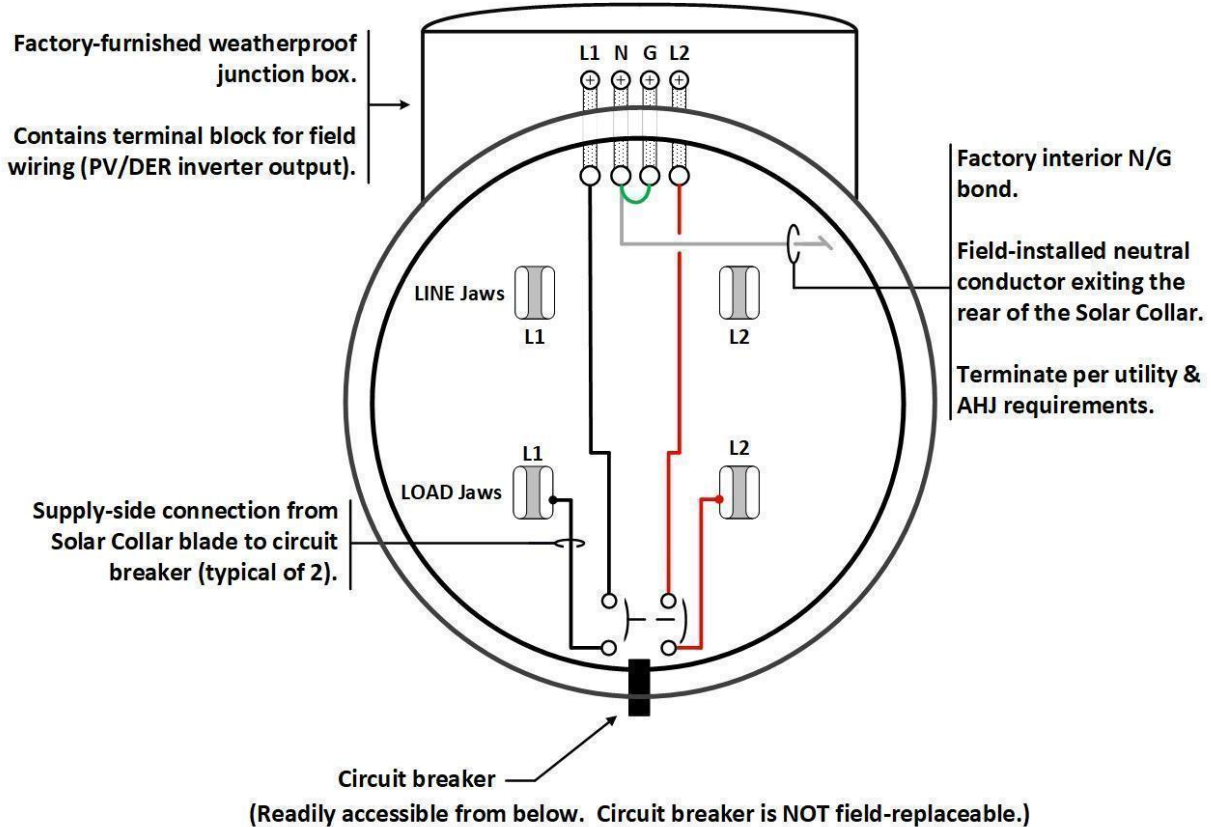

NOTE – The Solar Meter Adapter creates a supply side PV/DER interconnection on the load side of the billing meter. Interconnection at the line side of the billing meter is available for utility-owned systems only. The Solar Meter Adapter contains a factory-installed neutral-to-ground bond.



WARNING – Only install the Solar Meter Adapter with the junction box at the top and the integrated circuit breaker at the bottom. Do not install the Solar Meter Adapter in any other orientation.

The Solar Meter Adapter creates a connection to the supply side of the service disconnect as shown in **Figure 2**.

Figure 2 – Conceptual Supply-Side Solar PV Interconnection

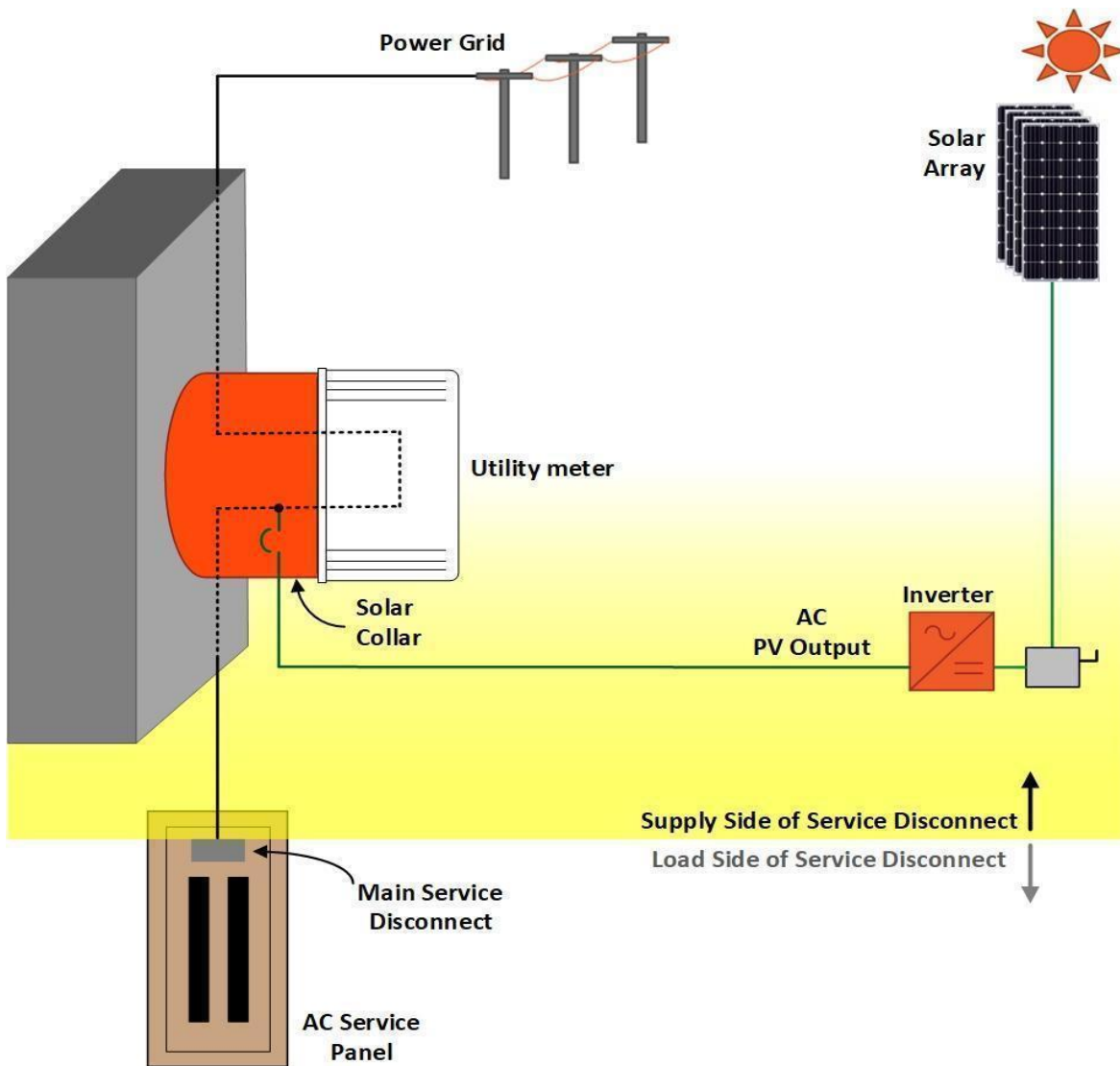

BOX CONTENTS

The package contains the following items. Verify the contents are complete before proceeding with installation:

Qty.	Item
------	------

- | | |
|---|---|
| 1 | Solar Meter Adapter. |
| 1 | Quick-connect and quick-release junction box with a 1" threaded closure plug. |
| 1 | Locking ring for attaching the meter to the meter collar. |
| 1 | Neutral pigtail, white, #6 AWG THHN stranded copper. |
| 2 | Tamper-resistant seals. |
| 1 | Label with installation reminders and a QR code to access installation manuals. |

1. Attach the white #6 AWG pigtail from the rear of the Solar Meter Adapter to a neutral point inside of the meter socket. The neutral pigtail must have a minimum ampacity as the line conductors protected by the Solar Meter Adapter internal circuit breaker.
2. Use a method approved by the utility and the authority having jurisdiction (AHJ).



WARNING – It is the responsibility of the Solar Meter Adapter installer to ensure a white #6 AWG pigtail is installed with every unit.



NOTE - More information regarding the neutral connection is contained in the "[INSTALL THE NEUTRAL LEAD](#)" section of this document.

INSTALLATION PREPARATION

SITE INSPECTION

There are several types of existing residential meter sockets suitable for Solar Meter Adapter installation. Some common types, namely single gang, multi-gang, and combination meter socket/load centers are covered in this section. All three are available in ringless and ring type configurations.

Begin assessing the suitability of a meter socket by ruling out two instances:

1. Rule out shallow meter sockets (sometimes referred to as “button” or “puck-type” meter sockets) as shown in **Figure 3**. They lack the interior space and means to accommodate a neutral pigtail.

Figure 3 – Shallow Meter Socket (Not Recommended)



2. Rule out meter sockets with inadequate space to install a #6 AWG neutral pigtail, signs of damage, excessive rust, evidence of loose or damaged service conductors, and enclosures loosely secured to the structure.

3. Confirm if the utility is restricting Solar Meter Adapter usage to ringless (**Figure 4**) or ring type (**Figure 5**) meter sockets. The Solar Meter Adapter supports both configurations.

Figure 4 – Single Gang Ringless Meter Socket



Ringless meter sockets use a small raised flange to hold the meter in place with the cover closed. They do not use a separate locking ring.

Ringless meter sockets are locked through a sliding lever as shown here, or by other means implemented by the utility.

Figure 5 – Single Gang Ring Type Meter Socket



Ring type meter sockets have an extruded flange on the cover...



...for a locking ring to secure the utility meter.

4. Confirm if multi-gang meter sockets (**Figure 6**) are on the utility's approved equipment list. They may present additional neutral wiring and service access issues over single gang meter sockets. ConnectDER recommends researching the manufacturer's documentation for potential compatibility.

Solar Meter Adapter compatibility with multi-gang meter sockets may be permitted by the utility on a case-by-case basis. Care must be taken to ensure that the Solar Meter Adapter junction box may be inserted and disconnected (lifted up a minimum of 2") and the field wiring raceway does not block access to circuit breakers and/or the removal of meter socket covers.

Multi-gang meter sockets may accommodate only the top socket, or left and right sockets, or none at all.

Figure 6 – Multi-Gang Meter Sockets



5. Confirm if combination meter socket/load centers (**Figure 7**) are on the utility's approved equipment list. They may present additional neutral wiring and service access issues over single gang meter sockets. ConnectDER recommends researching the manufacturer's documentation for potential compatibility.

Figure 7 – Combination Meter Socket/Load Centers



NOTE - The neutral pigtail from the Solar Meter Adapter is normally terminated in the meter socket compartment. The neutral pigtail is required as part of the installation and is a component of the Solar Meter Adapter itself; therefore, it should be permitted in and confined to the metering compartment. Check with the AHJ and utility to verify if the neutral connection must remain entirely within the meter socket compartment, or if it may cross any barrier to the customer premises wiring section.

6. A Solar Meter Adapter shall not be installed on meters already equipped with a socket adapter (**Figure 8**).

Figure 8 – Existing Meter and Socket Adapter



7. Account for other considerations:
 - a. Check with the utility for other potential meter collar prohibited installations. Do not install a Solar Meter Adapter where it is subject to physical damage.
 - b. Verify the Solar Meter Adapter model number(s) approved for use by the utility.
 - c. Verify the meter socket is accessible with adequate working clearance. The Solar Meter Adapter extends the billing meter 4.6 inches forward from the meter socket.
 - d. Check with the utility and the AHJ before installing a Solar Meter Adapter indoors. The Solar Meter Adapter contains an overcurrent device. Overcurrent devices are not permitted in bathrooms, over steps of a stairway and where subject to physical damage.
 - e. Verify the existing meter indicates the service voltage is 240volts, 200 amps maximum, 3-wire, and form 2S. Check with the utility in order to specify the correct meter form when ordering. (Some utilities are deploying 12S/five-jaw meter sockets but installing 2S/four-jaw net meters.)



WARNING – Do not alter the Solar Meter Adapter, conductors, or any other equipment in a manner that voids its listing or warranty.

PACKAGE INSPECTION

1. Inspect the box and verify the contents are complete and in good condition. Contact ConnectDER at RMA@connectder.com in case of damage or missing components.
2. Open the circuit breaker access door at the bottom of the Solar Meter Adapter and verify the ampere rating on the circuit breaker handle matches what was ordered.
3. Verify the Solar Meter Adapter has the correct meter form: 4-blade (form 2S)

ITEMS REQUIRED FOR SOLAR METER ADAPTER INSTALLATION



NOTE – The following items (provided by the installer) are required to install a Solar Meter Adapter into a meter socket:

Qty.	Item
1	One or more torque drivers to cover a range from 2 to 50 in-lbs.
1	7/64" hex key.
1	7/64" hex bit for use with a torque driver.
1	¼" flat blade screwdriver.
1	¼" flat blade bit for use with a torque driver.
1	Wire cutters.
1	Wire strippers.
1	Calibrated digital volt-ohmmeter or other suitable metering equipment.
1	Approved wiring connector to terminate the neutral pigtail inside the meter socket.
1 lot	Additional tamper-prevention seals.
1 lot	Insulation material for the neutral connection in the meter socket.
1	"Meter Grabber™" or equivalent tool to safely remove and reinstall the electric meter.

The items required to terminate PV/DER field wiring are listed in the "[INTERCONNECT THE PV/DER WIRING](#)" section of this document.

SAFETY EQUIPMENT

Follow your employer's requirements for personal protective equipment (PPE) and procedures. Comply with all applicable OSHA regulations. NFPA 70E (Standard for Electrical Safety in the Workplace) training is recommended for Solar Meter Adapter installers.

At a minimum, the installer should use the following PPE:

Qty.	Item
1	Safety glasses.
1	Full-face arc-flash shield.
1	Leather/rubber insulated electrical glove kit, minimum class 00 (500v AC).
1 lot	Calorie rated clothing for the site's arc flash rating.

ConnectDER recommends insulating live parts within the meter socket. Equipment examples include a safety cover for energized jaws, and a 1000V electrical insulation blanket that can be cut to size, temporarily applied, then taped and/or clamped into place. (Figure 9). Contact the serving utility for other safety tips or procedures.

Figure 9 – Protection From Energized Parts



INSTALLATION PROCEDURE



WARNING – Solar Meter Adapter installation must be performed by qualified personnel only. Electric shock, arc flash hazards, fire, serious injury or death may result if power is not removed from the meter socket prior to the Solar Meter Adapter installation.

REMOVE THE EXISTING UTILITY METER

In many service territories, the meter must be removed by the utility. An increasing number of utilities are permitting qualified personnel to remove the meter or install the Solar Meter Adapter. Contact the serving utility to verify the standard practice and/or schedule a visit by the utility or utility-approved personnel to remove the meter.

1. Notify the homeowner that power will be interrupted.
2. **Verify that the homeowner has all turned off and locked out/tagged out any alternate electrical sources such as backup generators, battery systems, etc.**
3. Turn off all power to the customer's loads at the service equipment, then open the main service disconnect to prevent arcing when removing (and reinstalling) the meter. **The line side meter socket jaws will remain energized.**
4. Remove all jewelry, put on the appropriate PPE, and follow your employer's safety procedures. Remove the tamper-prevention seals.
5. Remove the locking ring (for ring type meter sockets). For ringless meter sockets, remove the meter socket cover.
6. For lever bypass meter sockets, actuate the lever to facilitate meter removal.
7. Using a "Meter Grabber™" or similar tool, remove the electric meter and store it safely.
8. For lever bypass sockets, position the lever bypass to de-energize the load-side meter socket jaws.
9. Inspect the meter socket terminals for loose or broken wires, damaged jaws, and other signs of damage. Confirm the meter socket and service entrance conductors are in good condition and comply with utility requirements and local codes.

INSTALL THE NEUTRAL LEAD



- Attach the white #6 AWG pigtail from the rear of the Solar Meter Adapter to a neutral point inside of the meter socket. The neutral pigtail must have a minimum ampacity as the line conductors protected by the Solar Meter Adapter internal circuit breaker.
- Use a method approved by the utility and the authority having jurisdiction (AHJ).

WARNING ALL METER SOCKETS require a #6 AWG neutral conductor pigtail to be attached from the rear of the Solar Meter Adapter to a neutral point inside of the meter socket. Failure to install a #6 AWG neutral conductor may result in damage to equipment and will void the manufacturer's warranty.

It is the responsibility of the Solar Meter Adapter installer to ensure a white #6 AWG pigtail is installed with **every unit**.

1. Install a hot jaw safety cover and/or insulation blanket over live parts if the meter socket must remain energized.
2. Identify the method to terminate the neutral pigtail inside the meter socket. **Figure 10** depicts the interior of a typical 4-jaw meter socket. This model has a single accessory position, circled in yellow. A second accessory position may be available where the blue dot is shown.

Figure 10 – 4-Jaw Meter Socket

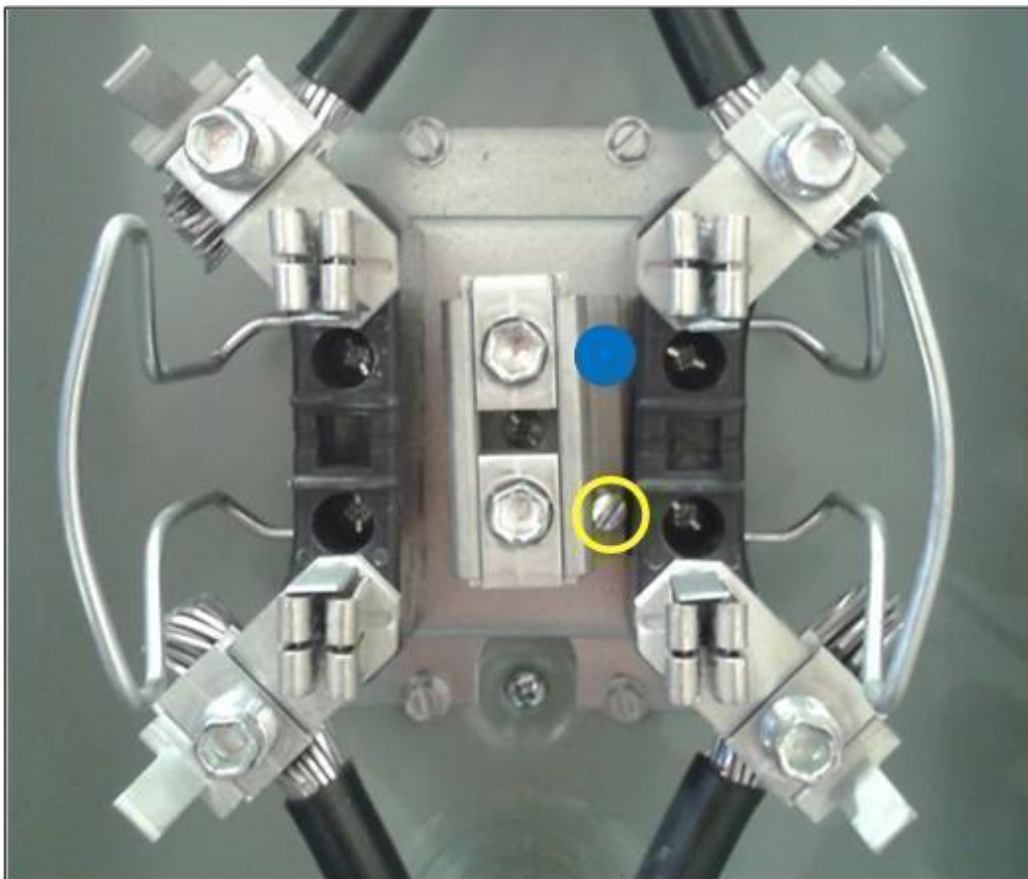

These accessory positions may contain pressure terminals or hardware for the connection of compression lug terminals. Terminate the neutral pigtail in accordance with the manufacturer's torque specifications.

If an accessory position is unavailable, two potential alternatives are suggested in **Figure 11**. Additional options may be available. ConnectDER does not endorse one method over another. All neutral connection wiring methods must be installed in accordance with the manufacturer's instructions and approved by the utility and AHJ.

Figure 11 – CU/AL Compatible Neutral Connection Options

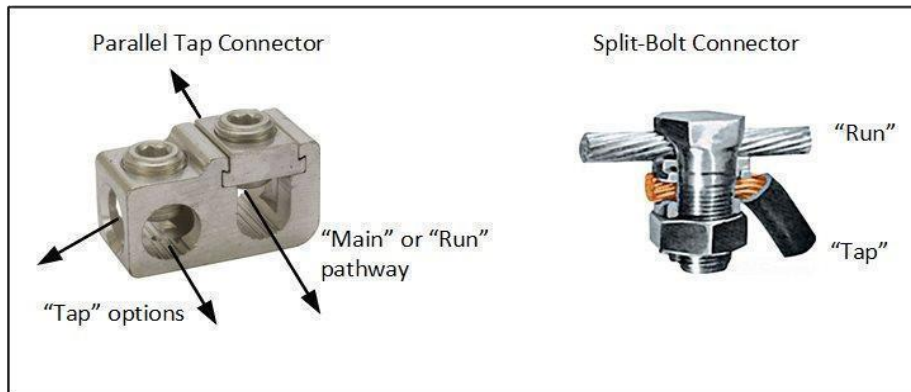

Both of these options are available with UL listing and:

- a. A component for the “main” or “run” conductor, namely the existing load side (of the meter) neutral conductor within the meter socket. The existing neutral conductor remains terminated within the meter socket while the parallel tap or split-bolt connector is installed.
- b. A termination point for the “tap” conductor (#6 AWG neutral pigtail to the Adapter).
- c. Assorted sizes to accommodate a range of run and tap conductors.
- d. Approval for use with both aluminum and copper conductors.



NOTE – As of January 1, 2023, the NEC requires pressure connectors and devices for splices and taps installed on service conductors shall be marked “suitable for use on the line side of the service equipment” or equivalent. If no product is available for that use case, the AHJ may permit products that comply with the most recent previous edition of the NEC that was adopted by the jurisdiction per NEC 90.4(D).



WARNING – Install all neutral pigtail termination employing a method acceptable to the utility and the AHJ.

3. Confirm energized parts are isolated with appropriate insulating material. See **Figure 9**.
4. Terminate the neutral lead to the meter socket using a spare accessory as shown in **Figure 12** (preferred), or by employing another method approved by the utility and the AHJ.

Figure 12 – Terminate the Neutral to the Meter Socket

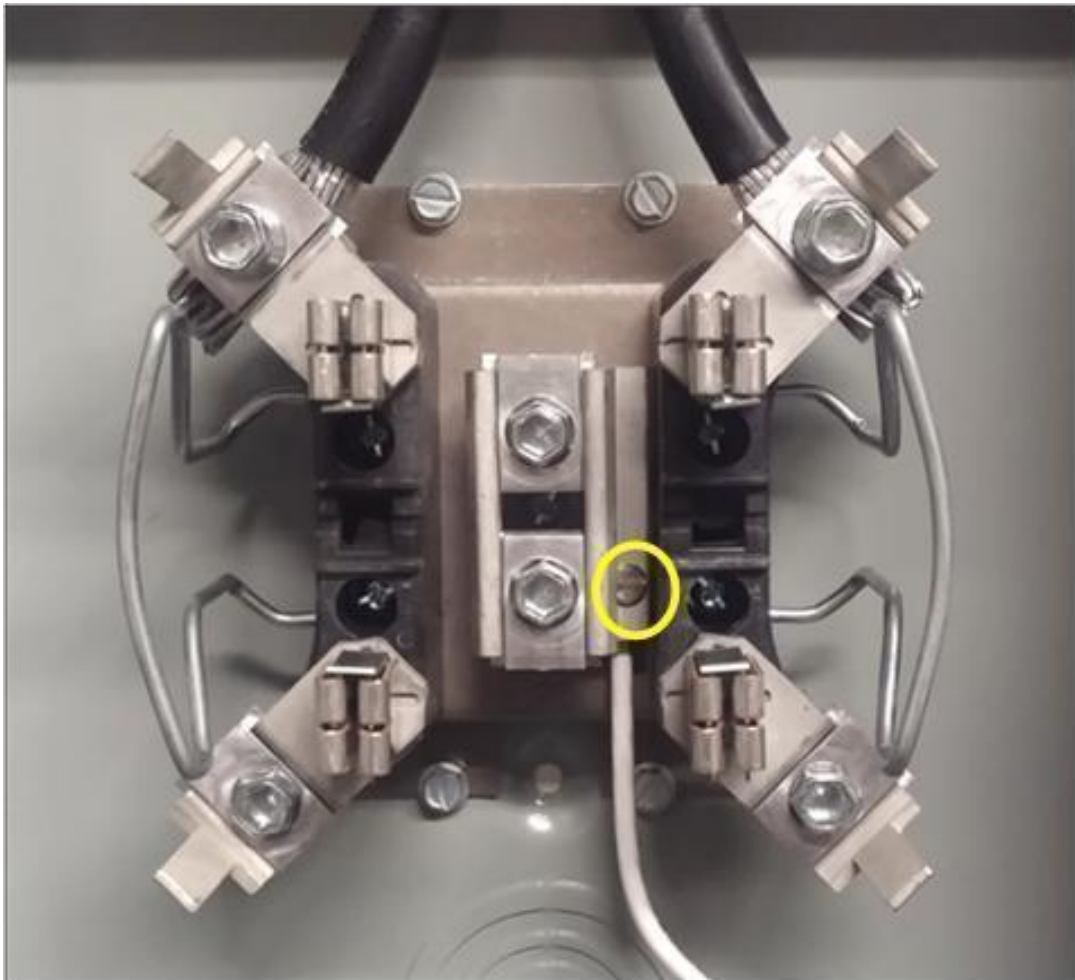

5. Trim, strip and route the neutral conductor within the meter socket (**Figure 13**) in a manner to avoid damaging the insulation. Position the other end to terminate near the top and center of the Solar Meter Adapter.

Figure 13 – Route the Neutral Within Meter Socket



6. For a parallel tap connector, apply an oxide inhibitor to the existing neutral conductor (for aluminum connections) as shown in **Figure 14**.

Figure 14 – Apply Oxide Inhibitor

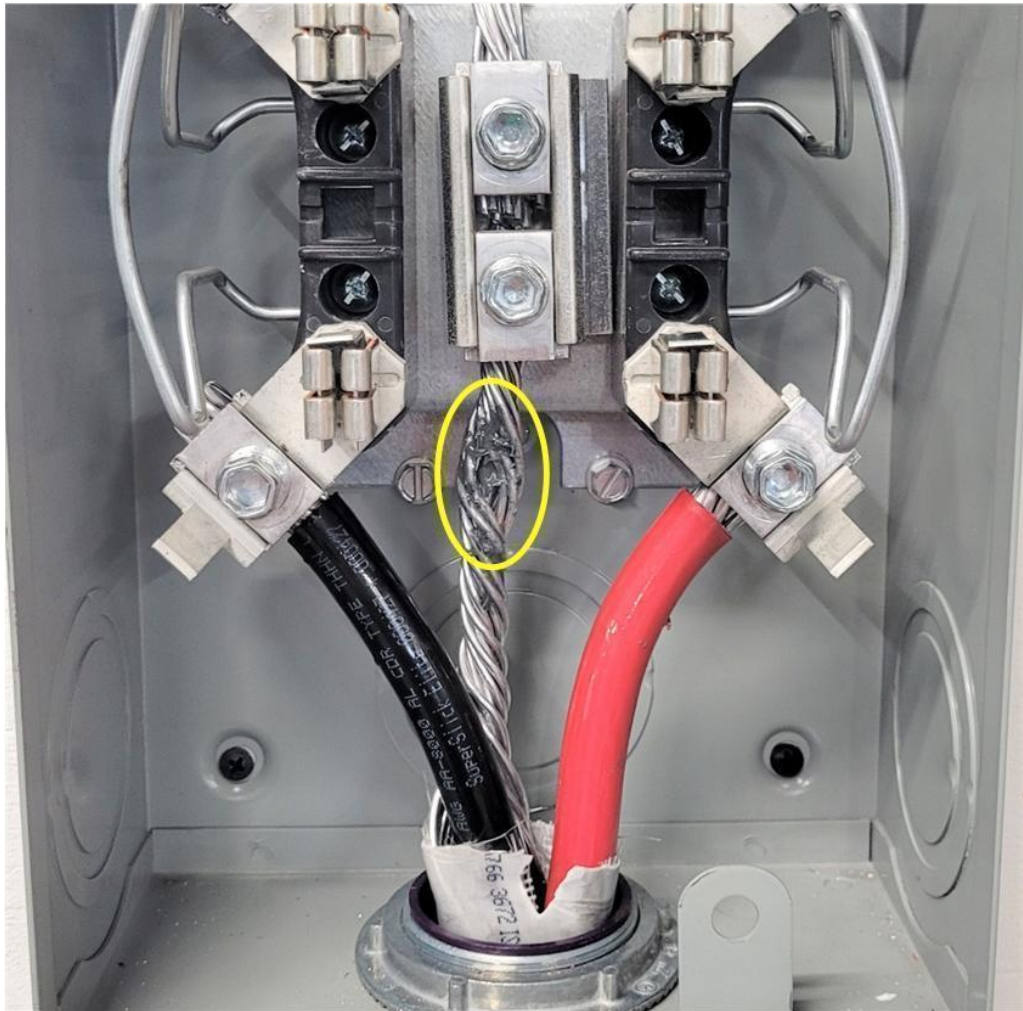

7. Remove the cover on the main/run side of the connector, place it around the existing neutral conductor and tighten the connection enough to hold it in place.
8. Strip and install the #6 AWG neutral pigtail to the tap side of the connector. Tighten both sides of the connector to the manufacturer's specifications.

9. Route the neutral conductor within the meter socket (**Figure 15**) in a manner to avoid damaging the insulation. Position the other end to terminate near the top and center of the Solar Meter Adapter.

Figure 15 – Parallel Tap Connection

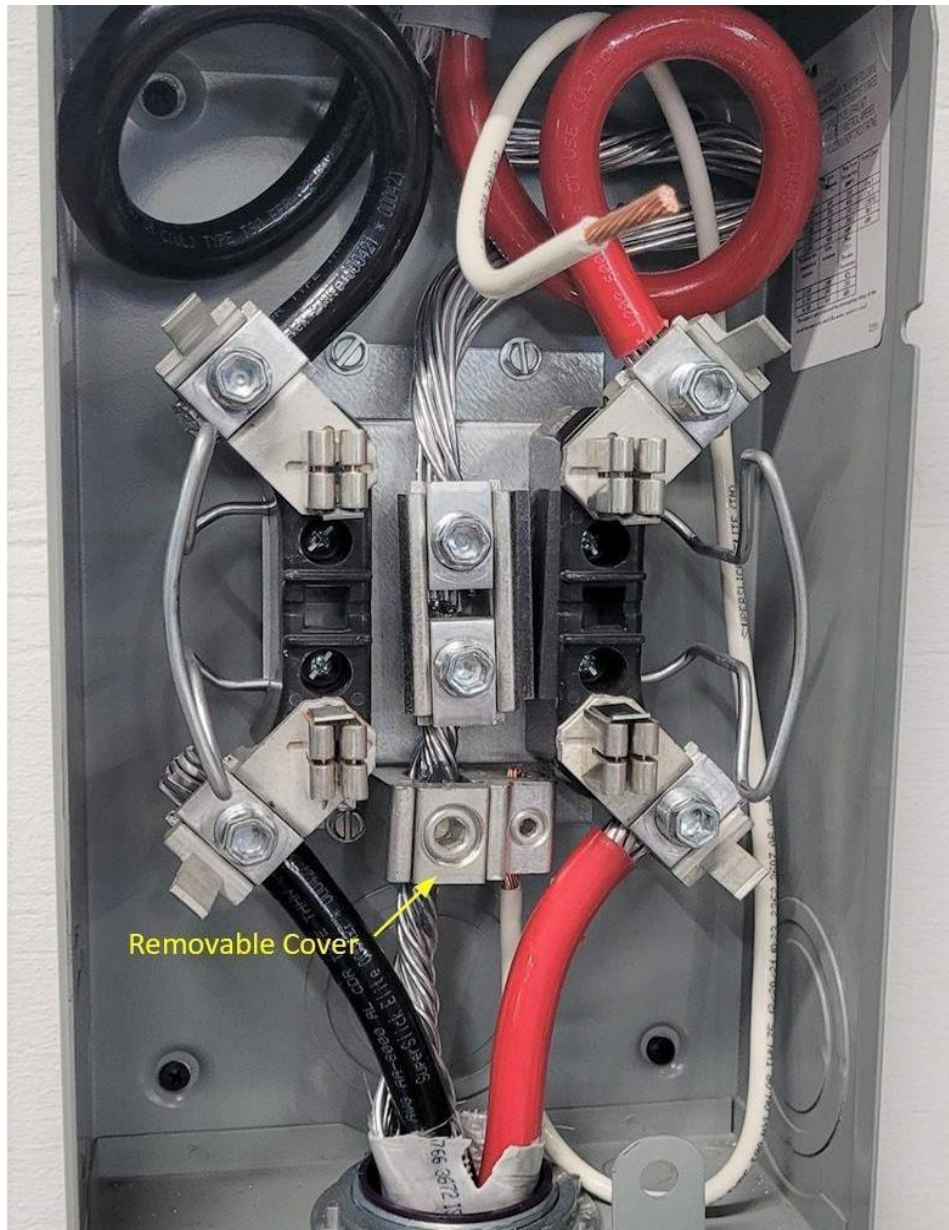

10. Keep the parallel tap connection away from exposed ungrounded parts. Insulating the completed neutral connection is recommended and may be required by the utility and/or AHJ. Use an approved cover or insulate with mastic tape, or a combination of rubber tape and electrical tape, or other approved method. **See Figure 16.**

Figure 16 – Neutral Parallel Tap Insulation Examples



11. For a split-bolt connector, disassemble the connector, apply an oxide inhibitor (for aluminum conductor connections), and install the main portion around the existing neutral conductor as shown in **Figure 17.**

Figure 17 – Split-Bolt Connector Main/Run

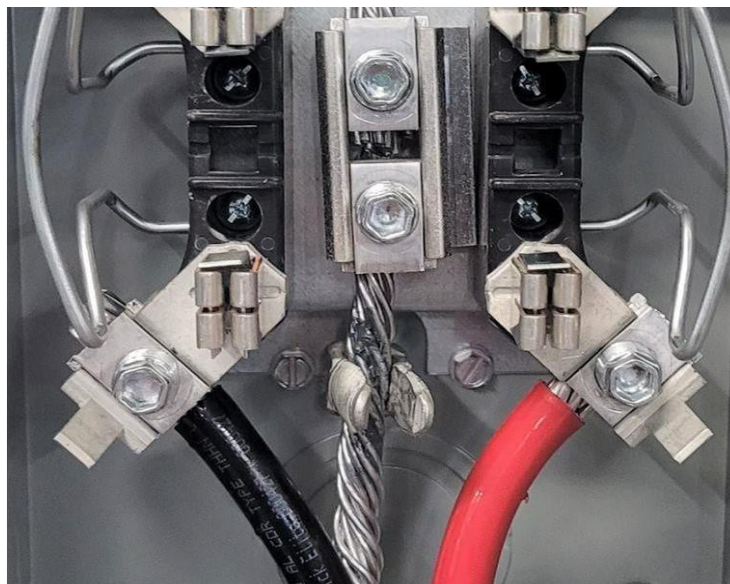

12. Next, install the separator for the main/run and tap conductors as shown in **Figure 18**.

Figure 18 – Run and Tap Separator



13. Strip and place the #6 AWG neutral pigtail against the separator, and screw on the final component against the tap conductor as shown in **Figure 19**. Tighten to the manufacturer's specifications.

Figure 19 – Split-Bolt Connection



14. Keep the split-bolt connection away from exposed ungrounded parts. Insulating the completed neutral connection is recommended and may be required by the utility and/or AHJ. Use an approved cover or insulate with mastic tape, or a combination of rubber tape and electrical tape, or other approved method. **See Figure 20.**

Figure 20 – Neutral Split-Bolt Insulation Examples



15. For ring type meter sockets, reinstall the meter cover while routing the neutral lead through the cover opening (**Figure 21**). For ringless meter sockets, connect the neutral lead to the Solar Meter Adapter before reinstalling the cover (see step #18).

Figure 21 – Reinstall the Ring-Type Cover



16. Remove the junction box from the Solar Meter Adapter body by hand, pulling it straight upward.
17. Terminate the neutral lead to the Solar Meter Adapter using a ¼" flat blade screwdriver as shown in **Figure 22**.

Figure 22 – Terminate the Neutral to Solar Meter Adapter



18. Torque the #6 AWG neutral connection at the Solar Meter Adapter to 40 in-lbs.

INSTALL THE SOLAR METER ADAPTER INTO THE METER SOCKET

1. Confirm the Solar Meter Adapter circuit breaker is in the open (OFF) position. See **Figure 23**.

Figure 23 – Verify Solar Meter Adapter breaker is open (OFF)



2. Remove the temporary insulation protection.
3. Shut the circuit breaker cover.
4. Ensure the Solar Meter Adapter is positioned with field wiring contacts at the top and circuit breaker at the bottom.
5. Align the Solar Meter Adapter stabs with the socket jaws, ensuring all wire and additional terminations will avoid non-insulated parts within the meter socket.
6. Quickly and forcefully insert the Solar Meter Adapter into the meter socket.

7. Ensure the Solar Meter Adapter stabs are securely seated in the meter socket jaws. The Solar Meter Adapter should not move freely once properly seated.
8. For ringless meter sockets, reinstall the meter socket cover over the Solar Meter Adapter, taking care not to cause damage. Tight clearances may necessitate manipulation of the cover around the Solar Meter Adapter. See **Figure 24**.

Figure 24 – Reinstall the Meter Socket Cover



9. For ring type meter sockets, install a locking ring to secure the Solar Meter Adapter to the meter socket cover.

10. Verify the meter socket cover is fully engaged. Confirm the circuit breaker cover opens freely. See **Figure 25**.

Figure 25 – Circuit Breaker Cover



REINSTALL THE UTILITY METER



WARNING - This will energize the line side terminals at the service disconnect. Using a "Meter Grabber™" or similar tool.

1. Align the utility meter stabs with the Solar Meter Adapter jaws.
2. Firmly press the meter into the Solar Meter Adapter, ensuring a secure fit.
3. Install a lock ring to secure the utility meter to the Solar Meter Adapter.

VERIFY THE VOLTAGE AT THE SOLAR METER ADAPTER

1. Place the Solar Meter Adapter circuit breaker in the closed (ON) position.
2. Using proper PPE, verify the presence of appropriate service voltage at the top of the meter collar as shown in **Figure 26**. Check L1-L2, L1-N/G, and L2-N/G. Do not proceed with installation until the voltages meet expected values.

Figure 26 – Verify the Voltage at the Quick-Connect Contacts

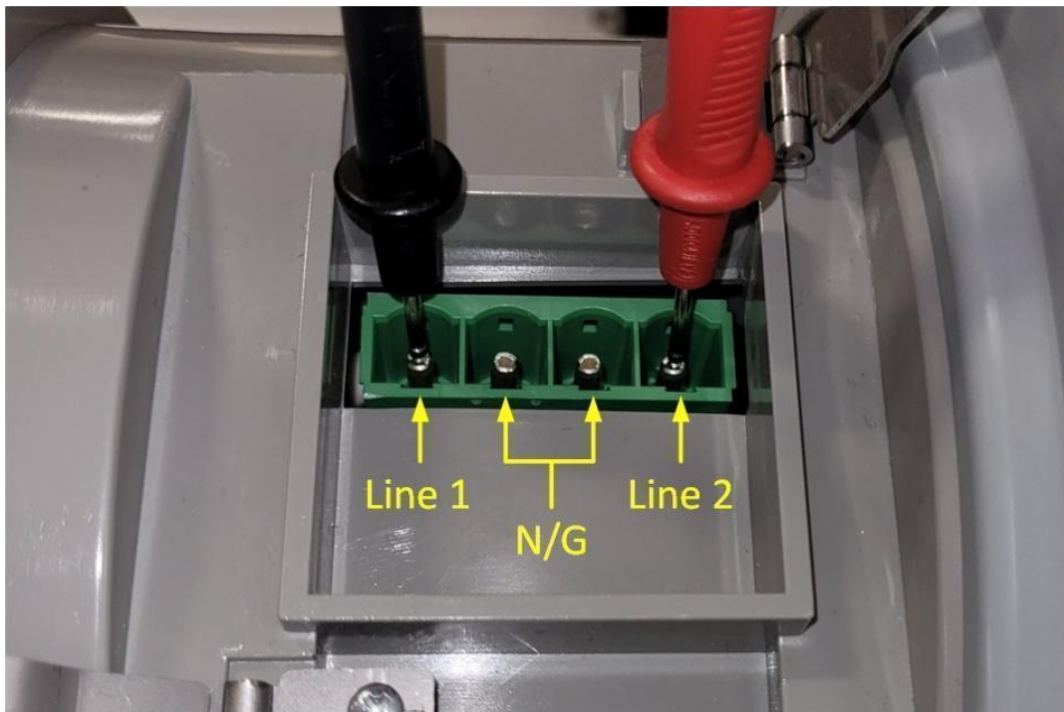

3. Return the Solar Meter Adapter circuit breaker to the open (OFF) position, then verify the contacts are deenergized.
4. Shut the cover to the circuit breaker and lock it out until the PV/DER wiring is interconnected.

INSTALL THE SOLAR METER ADAPTER JUNCTION BOX

1. If the PV/DER wiring is to be performed at this time, refer to the “[INTERCONNECT THE PV/DER WIRING](#)” section of this document. Otherwise, complete the installation to make the assembly weatherproof and safe.
2. Confirm the Solar Meter Adapter circuit breaker is in the open (OFF) position and locked out.
3. Flip the junction box locking clasps open as shown in **Figure 27**.

Figure 27 – Junction Box Locking Clasps



4. Confirm the 7/64" screws on the bottom of the junction box (**Figure 28**) are torqued to 6 in-lbs. in case they loosened during shipping.

Figure 28 – Torque the Junction Box Screws



5. Install the junction box by aligning its contact pins with those embedded in the Solar Meter Adapter body and pressing firmly downward. Seal the conduit entry hole with the provided threaded plug as shown in **Figure 29**.

Figure 29 – Junction Box Installation



6. Reposition the locking clasps to secure the junction box.
7. Install tamper-prevention seals on the lock rings, the meter socket cover, and the junction box clasps as shown in **Figure 30** unless directed otherwise by the utility or the AHJ.

Figure 30 – Tamper-Prevention Seals



8. Verify with the homeowner that any alternate/backup power solutions are in position to restore utility power to the service equipment, then restore utility power.
9. The installation for Solar Meter Adapter is complete and ready for PV/DER interconnection.

INTERCONNECT THE PV/DER WIRING

ITEMS REQUIRED FOR PV/DER INSTALLATION



NOTE – The following items (provided by the installer) are required to connect PV/DER wiring to a Solar Meter Adapter:

Qty.	Item
1	One or more torque drivers to cover a range from 2 to 20 in-lbs.
1	7/64" hex key.
1	7/64" hex bit for use with a torque driver.
1	3/16" flat blade screwdriver.
1	3/16" flat blade bit for use with a torque driver.
1	Wire cutters.
1	Wire strippers.
1	Calibrated digital volt-ohmmeter or other suitable metering equipment.
1 lot	Tools and field wiring materials to install PV/DER raceway to the Solar Meter Adapter junction box. Use 1" liquidtight flexible nonmetallic conduit type LFNC with a straight connector to enter the solar meter adapter junction box.
1 lot	Tamper-prevention seals.

SAFETY EQUIPMENT



WARNING – PV/Interconnection wiring must be performed by qualified personnel only. Follow your employer's requirements for personal protective equipment (PPE) and procedures.

INSTALL THE PV/DER WIRING AT THE SOLAR METER ADAPTER JUNCTION BOX

 NOTE – The reversible junction box enables conduit entry from the left or right side of the meter. Use a straight connector at the junction box. **IMPORTANT: Provide enough slack (i.e., a service loop or “drip loop”) in the flexible conduit to permit junction box removal (pulling straight up a minimum of 2 inches).**

 NOTE – The Solar Meter Adapter should be wired **first**, and the other end (such as an ac PV disconnect switch or PV production meter) second. It is easier to terminate the conductors at the Solar Meter Adapter junction box by wiring it first.

1. Use type THHN insulated, **copper** conductors only. Select the wire gauge by following its 75°C ampacity .
2. Verify the PV/DER power production source wiring is clear of faults using suitable metering equipment.
3. Remove jewelry, put on the appropriate PPE, and follow your employer’s safety procedures.
4. Place the Solar Meter Adapter circuit breaker in open (OFF) position, shut the breaker cover and lock it out following your company’s lockout/tagout (LOTO) practices.
5. Follow procedures for removing the tamper-prevention seals from the junction box clasps.
6. Flip open the junction box clasps.
7. Pull the junction box up by hand to remove it from the Solar Meter Adapter body. Once removed, ensure that no moisture or debris enters the pin are of the collar while wiring the junction box. See **Figure 31** on the next page.

Figure 31 – Junction Box Removed



8. Using a 7/64" hex key, remove the bottom cover of the junction box, taking care not to damage the gasket material surrounding the green contact assembly. TAKE CARE NOT TO LOSE THE 7/64" SCREWS.
8. Remove the 1" threaded plug from the junction box.
9. Install the type LFNC straight conduit connector onto the junction box, then pull the PV/DER wiring through the conduit connector.

10. Strip the insulation exposing wire 18mm (approximately 0.71"). See **Figure 32**.

Figure 32 – Wiring at Junction Box



11. Slide each conductor into its individual wiring bay. Ensure all strands from each conductor enter the screw terminal area.
12. Tighten the screw terminals, ensuring that only the copper conductor is being compressed (**not** the insulation).
13. Terminate the wiring to the terminal block and tighten by hand to hold the conductors in place.
14. Perform a gentle “pull-test” by hand to ensure there are no loose connections.
15. Torque each screw terminal to 15 in-lbs. See **Figure 33** on the next page.

Figure 33– Wiring at Terminal Block

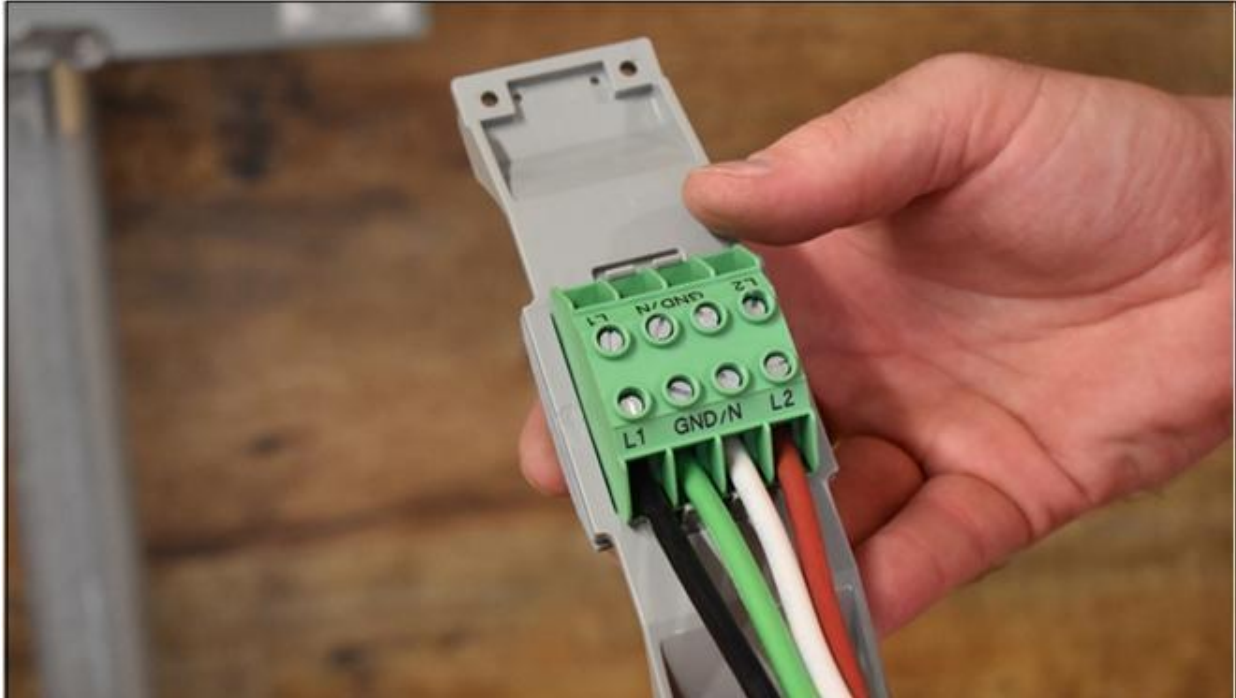

16. Route the excess slack back through the conduit connector and reassemble the junction box.
17. Reinstall the 7/64" hex cap-head screws and torque to 6 in-lbs.
18. Slide the raceway over the wiring and secure it to the raceway connector.

INSTALL THE JUNCTION BOX

1. Align the pins of the junction box over the pins embedded within the Solar Meter Adapter as shown in **Figure 34**.

Figure 34 – Align the Junction Box Pins



2. Press firmly down on the junction box and ensure it is securely seated.

3. Secure the junction box with the metal clasps in front of and behind the box. See **Figure 35**.

Figure 35 – Secure the Clasps



4. Install two tamper-resistant seals – one each at the front clasp and rear clasp as shown in **Figure 36**.

Figure 36– Tamper-Prevention Seals



COMPLETE THE CONDUIT AND WIRING, ENERGIZE AND TEST

1. Install, support, and terminate the other end of the raceway and conductors to the next enclosure (such as an ac PV disconnect or PV production meter). **IMPORTANT: Provide enough slack (i.e., a service loop or "drip loop") in the flexible conduit to permit junction box removal (pulling straight up a minimum of 2 inches).**
2. Remove the lockout/tagout (LOTO) device and place the Solar Meter Adapter circuit breaker in the closed (ON) position.
3. Test for proper voltage and polarity at the next enclosure.
4. Follow your company's safety procedures to extend the wiring as needed.
5. Follow the manufacturer's instructions to commission the PV/DER system.

APPENDIX – SOLAR PV INTERCONNECTION WIRING EXAMPLE

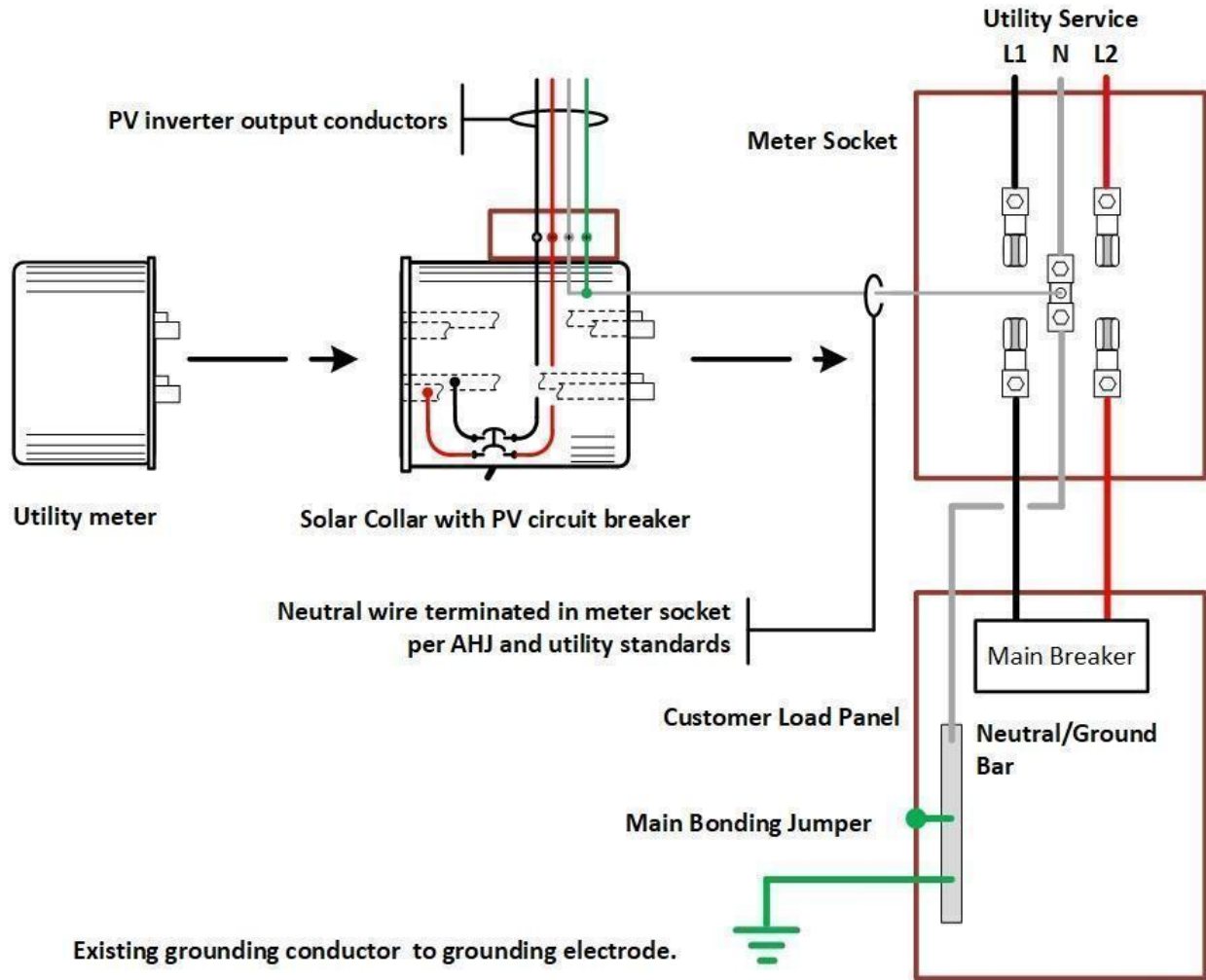

NOTE – The Solar Meter Adapter creates a supply-side PV/DER interconnection on the load side of the meter. The Solar Meter Adapter contains a factory-installed neutral-to-ground bond.

SOLAR METER ADAPTER MODEL NUMBERS

FORM 2S METER TYPES					
Model Number	Product Version	Grid Interconnection	No. of Jaws	AIC Rating	Overcurrent Protection Rating
M-B-4-10-40	Simple	Load Side	4 Jaws	10kAIC	40 Ampere
M-B-4-10-60	Simple	Load Side	4 Jaws	10kAIC	60 Ampere

SOLAR METER ADAPTER SPECIFICATIONS

MECHANICAL SPECIFICATIONS		UTILITY INTERACTIVE SOURCE RATINGS	
ENCLOSURE RATING	NEMA 3R	MAXIMUM POWER	11.52 KW AC
ENCLOSURE TYPE	Injection molded polycarbonate, UL 94 V0 flame rating	MAXIMUM VOLTAGE	240V
COOLING	Natural convection	MAXIMUM CONTINUOUS PV CURRENT	48A
DIMENSIONS (H X W X D)	6.7 x 6.7 x 4.6in collar only 8.1 x 6.7 x 4.6in with junction box	CONTINUOUS COMBINED CURRENT, PV/GRID	180A
WEIGHT	3.6 lbs. (1.6kg)	INVERTER WIRING TERMINATION	Terminal block
SHIPPING WEIGHT	5.1lbs. (2.3kg)	GRID CONNECTION TYPE	Split-Ø/3W (2S/4-jaw)
MOUNTING SYSTEM	Blade interface with 4-jaw meter socket	GRID TERMINATION METHOD	Blade interface with meter socket for L1/L2, pigtail for neutral
ELECTRIC METER COMPATIBILITY	Type 2S	FIELD TERMINAL RATING	75°C
METER SOCKET COMPATIBILITY	Ringless and ring-type meter sockets		
DER INTERFACE POINT	Factory configured, load side only		
CONDUIT CONNECTION	Threaded for single 1" NPT fitting, use reducer bushings as needed		
TERMINAL CONNECTIONS	L1, L2, N, G; Up to #6 AWG wire		
SAFETY INFORMATION		OVERCURRENT PROTECTION	
APPLICABLE SAFETY STANDARDS	UL 414 – Meter Sockets	TYPE	Eaton BR, thermal magnetic 120/240V, externally resettable
FILE NUMBER (STANDARDS)	E361188	OVERCURRENT RATINGS AVAILABLE	40A, 60A
AMBIENT AIR OPERATING TEMPERATURE RANGE	-22°F to 158°F (-30°C to 70°C)	CURRENT INTERRUPTING RATING	10k AIC rating
AMBIENT AIR STORAGE TEMPERATURE RANGE	-40°F to 176°F (-40°C to 80°C)		



CONTACT

ConnectDER, Inc.

support@connectder.com

HEADQUARTERS

103 West Broad Street

Suite 250

Falls Church, VA 22046

SERVICE CENTER/RMA ADDRESS:

2037 Washington Avenue

2nd Floor Rear

Philadelphia, PA 19146